

# PRODUCTS DATA

● MOUNTING METHODS OF PUNCHES AND DIES .....	1589
● CHARACTERISTICS OF PUNCHING TOOLS .....	1591
● SHAPES AND DIMENSIONS OF PUNCHES & DIES .....	1592
● CALCULATION OF PUNCH STRENGTH .....	1593
● DURABILITY OF PUNCHES .....	1597
● DICOAT® PUNCHES .....	1599
● [QUALITY IMPROVEMENT] IMPROVED COATING PUNCHES .....	1601
● COATING PUNCHES — TiCN — .....	1604
● WPC® TREATMENT AND HW COATING PUNCHES .....	1605
● RW COATING PUNCHES — Al-Cr TYPE COATING — .....	1607
● DLC COATING PUNCHES .....	1609
● PUNCHES FOR HEAVY LOAD, TAPERED HEAD PUNCHES .....	1611
● CONDITIONS UNDER WHICH FRACTURE, BREAKAGE, AND ABNORMAL WEAR ARE LIKELY TO OCCUR .....	1613
● CARBIDE TOOL MATERIALS FOR WEAR RESISTANCE .....	1614
● SELECTION OF BUTTON DIES .....	1615
● SCRAP RETENTION REVERSE TAPER DIES .....	1617
● SCRAP RETENTION DIES .....	1619
● NON-CLOGGING BUTTON DIES & SCRAP VACUUM UNITS .....	1621
● NOTES ON ASSEMBLING STRIPPER GUIDES .....	1623

# [PRODUCTS DATA] MOUNTING METHODS OF PUNCHES AND DIES

## Punch mounting methods

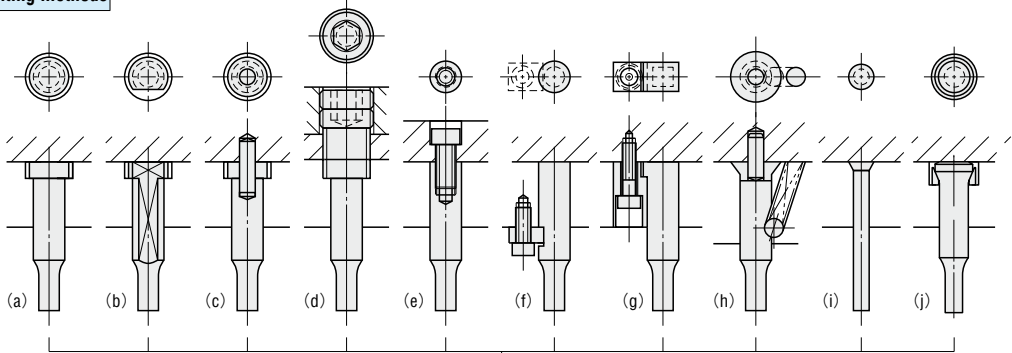

## Punch holding methods

Based on punch plate (Fig. 1)

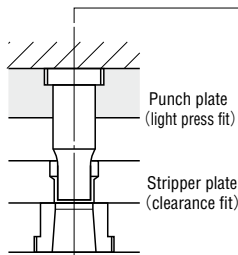

Based on stripper plate (Fig. 2)

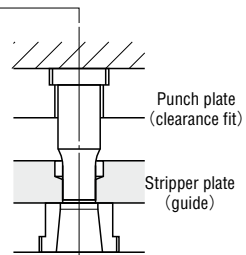

## Punch guiding methods

No guide

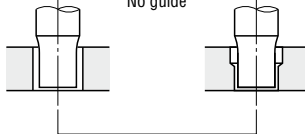

With punch guide  
 $\ell = (1 \sim 2)P$

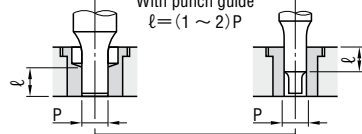

## Die mounting methods

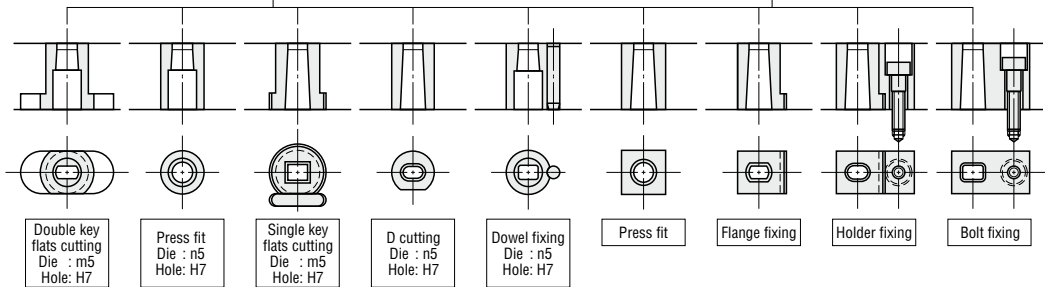

## ■ Punch mounting methods

Type	Mounting method	Remarks	Page	
a	Flange fixing	The position and perpendicularity of the punch are maintained by the shank, and the head prevents the punch from coming off.	Standard type for round punches Reliable in preventing the punch from coming off.	P. 55~
b	Flange (positioning with a key flat)	The position and perpendicularity of the punch are maintained by the shank, and the head prevents the punch from coming off.	The position is determined by a key flat shank machined by WEDM and inserted into a hole.	P. 101~
c	Locating with dowel pin	Positional accuracy is achieved with the dowel pin, and the head fastens the punch in place.	The dowel hole is created by NC machining, allowing easy positioning. This type is often used for automobile dies.	P. 113~
d	Fixing with adjustment pins	The position and perpendicularity of the punch are maintained by the shank, and the head is fastened with a bolt.	This type allows the punch to be replaced easily.	P. 831~
e	Bolt fixing (tapping)	The position and perpendicularity of the punch are maintained by the punch plate, and the bolt prevents the punch from coming off.	Highly accurate and also reliable in preventing the punch from coming off. Not suitable for thin punches or punching for heavy load.	P. 197~
f	Key fixing	The groove of the punch is fixed in place with a key.	This type allows the punch to be installed and replaced easily. This type is often used for precision dies based on the stripper plates.	P. 211~
g	Holder fixing	The head of the punch is screwed in place with a holder.	This type allows the punch to be replaced easily. This type is used in cases when the clearance between the punch plate and stripper plate is small.	P. 465~
h	Ball lock	A steel ball inside a special retainer locks the punch groove to fasten the punch in place.	The punch can be mounted and removed easily by lifting up the steel ball with a pin. This type is often used for automobile dies.	P. 771~
i	Taper fixing	A tapered part prevents the punch from coming off.	This type is inexpensive because the head is produced by upsetting. This type is often used for quill punches.	P. 233~
j	Taper+ring	A special ring supports the tapered part.	The special ring allows tapered head punches with high-strength heads to be easily installed.	P. 169~

## ■ Punch holding methods

- Based on punch plate : This is the most commonly-used method, and because the punch is press-fit into the punch plate, dies can be produced easily. If the punch concentricity (Fig. 1) or accuracy of hole machining is poor, variation is likely to occur in the clearance between the punch and die. As a result, this method is not suitable for cases when clearance between the punch and die is small.
- Based on stripper plate : This method is primarily used for thin, high-precision dies. (Fig. 2) The punch tip is guided by the stripper plate, which is located close to the punch and die, making it possible to minimize precision error. The punch is held in the punch plate by a clearance fit.

## ■ Methods of adjusting punches and dies

- Adjustments at regrinding  
If the punch shim, punch spacer, and die spacer are used, the height of the punch and die will not change when regrinding is performed.
- Adjustments of clearance  
The position of the die can be easily adjusted by using the position-adjustment shims or liners.

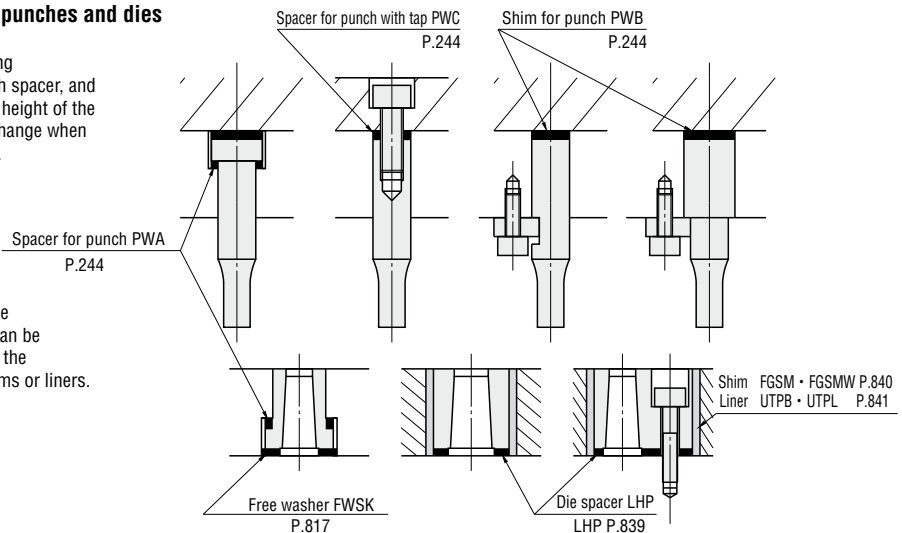

# [PRODUCTS DATA] CHARACTERISTICS OF PUNCHING TOOLS

## ■ The necessary characteristics of a punching tool

Include good wear resistance, high compression resistance, high impact resistance and toughness, and high fatigue strength.  
Punching tool materials must be selected to suit the punching conditions, such as the production quantity, workpieces, and lubrication.

## ■ Characteristics of tool steel

Alloy tool steel	SKD11	12% Cr SKD11 has excellent wear resistance and good hardenability, which leads to reduced deformation. This is the type of tool steel most often used.
	SKD11 (improved)	High-temperature tempering results in hardness of HRC60~63, increasing the toughness of the steel.
High-speed tool steel	SKH51	SKH51 is the type of high-speed steel most often used. It features excellent wear resistance and toughness.
Powdered high-speed tool steel	SKH40	Powder metallurgical techniques yield powdered steel with an even structure, and because it contains large quantities of high alloying components (such as W, V, and Co) which were unavailable before, this steel has excellent toughness, wear resistance, and fatigue strength.
Carbide	V30	Compared with ordinary steel, this material has higher hardness and superior wear resistance, compression resistance, rigidity, and heat resistance. However toughness is poor, and if this material is selected incorrectly, its full performance cannot be achieved.

## ■ Effects of alloying elements

Element	Effect
C	Forms carbides in combination with Cr, W, Mo, V, and other elements, providing wear resistance. Hardness increases with higher content.
Cr	Improves wear resistance, corrosion resistance and hardenability.
Mo, W	Forms hard complex carbides in combination with Fe, Cr, and C, improving wear resistance, hardenability, and hardness at high temperatures.
V	Improves wear resistance and toughness.
Co	Improves high-temperature hardness and tempering hardness.
Mn	Improves hardenability and toughness.

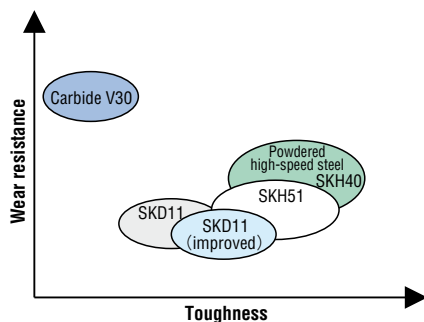

## ■ Characteristics of punching tools

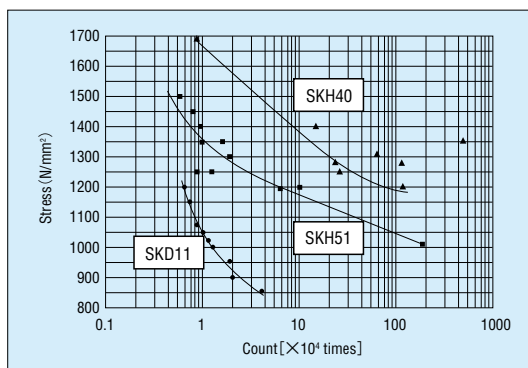

## ■ Fatigue strength of punching tools (rotating bending)

Fatigue strength varies largely depending on the conditions of surface treatment, heat treatment, and other factors. Use this diagram as a reference guide.

## ■ Material characteristics of punching tools

Item	M	Alloy tool steel		High-speed steel	Powdered high-speed steel	Carbide
		SKD11	SKD11 (improved)	SKH51	SKH40	V30
Chemical composition (%)	C	1.5	8% Cr die steel	0.85	1.3	Co : 12% Other : WC
	Cr	12		4.15	4	
	Mo	—		6.5	6	
	W	1		5.3	5	
	V	0.35		2.05	3	
	Co	—		—	8	
	Mn	0.45	0.35	—		
Hardening temperature [°C]		1000~1050	1020~1040	1180~1220	1120~1190	—
Tempering temperature [°C]		150~200	520~550	550~570	560~580	—
Hardness	HRC	60~63	60~63	61~64	64~67	1200—1350 HV
Traverse rupture force	N/mm <sup>2</sup>	3500	4500	4800	4500	2500
Young's modulus	N/mm <sup>2</sup>	210000	217000	219000	228600	540000
Density	g/cm <sup>3</sup>	7.72	7.87	8.11	8.07	14.4
Thermal expansion coefficient	×10 <sup>-6</sup> /°C	12.0	12.2	10.1	10.1	5.4
Thermal conductivity	W/m·k	29.3	23.7	20.6	23.8	72

Note: • The data presented here represents typical values; they are not guaranteed values.

• Powdered high-speed steel SKH40 has been standardized by JIS G 4403 : 2000.

(Examples include Hitachi Metal HAP40, Kobe Steel KHA30, Daido Steel DEX40, and Nachi-Fujikoshi FAX38.)

**Shapes of punches and dies**

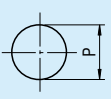
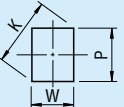
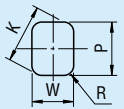
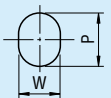
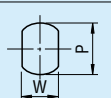
Shape	Profile length of tip $\ell$	Diagonal (circumscribing circle) K	Cross section area S
Round	 $\pi P$	P	$\pi P^2/4$
Square	 $2(P+W)$	$\sqrt{P^2+W^2}$	PW
Corner R	 $2\pi R + P + W - 4R$	$2R + \sqrt{(P-2R)^2 + (W-2R)^2}$	$PW - (4R^2 - \pi R^2)$
Oblong	 $\pi W + 2(P-W)$	P	$\frac{\pi}{4}W^2 + W(P-W)$
Key flat	 $2\sqrt{P^2-W^2} + (\pi P \sin^{-1}W/P)/90$	P	$\pi P^2/4 - (\pi P^2 - \cos^{-1}W/P)/360 + W/2\sqrt{P^2-W^2}$

**■ Finding the length of R (Y)**

① Length of punch R (Y)

Find Y from  $X = (D - P)/2$ .

$Y = \sqrt{X(20 - X)}$  ..... For R10

$Y = \sqrt{X(2R - X)}$  ..... For other than R10

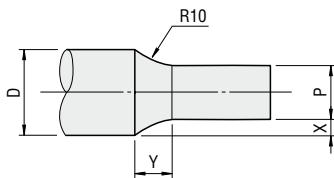

**Example 1: Finding Y for SPAS10-60-P6.80**

$$X = (D - P)/2 = (10 - 6.8)/2$$

$$= 1.6$$

$$Y = \sqrt{1.6(20 - 1.6)} \approx 5.426$$

② Length of pilot punch R (Y)

$Y = \sqrt{P(10 - P/4)}$  ..... For R10

$Y = \sqrt{P(R - P/4)}$  ..... For other than R10

● When  $P < 8$

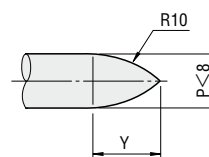

● When  $P \geq 8$ ,

Y is always 8 mm.

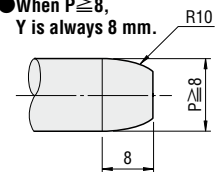

**Example 2: Finding Y for SPT5-20-P4.5**

$$Y = \sqrt{P(10 - P/4)}$$

$$= \sqrt{4.5(10 - 4.5/4)} \approx 6.32$$

# [PRODUCTS DATA] CALCULATION OF PUNCH STRENGTH ①

There are cases where trouble, such as punch tip breakage and flange fractures, occurs during the punching operation. Often the cause of this trouble is a lack of technical data concerning standard parts, or an error in the selection of the punching tool material or shape. In order to reduce the incidence of this kind of trouble, standards for correct punch use, with consideration for factors such as the fatigue strength of tool steel and concentration of stress at flanges, are presented here.

## 1. Calculation of punching force

### • Punching force P [kgf]

$$P = \ell t \tau \quad \dots \dots \dots (1)$$

$\ell$  : Pinching profile length [mm]  
(For a round punch,  $\ell = \pi d$ )

$t$  : Material thickness [mm]

$\tau$  : Material shearing resistance [kgf/mm<sup>2</sup>]  
( $\tau \cong 0.8 \times \text{Tensile strength } \sigma_B$ )

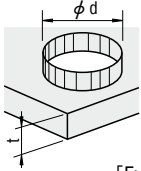

[Example 1] The maximum punching force P when punching a round hole of diameter 2.8 mm in a high-tensile steel sheet of thickness 1.2 mm (tensile strength 80 kgf/mm<sup>2</sup>), is the following. When  $P = \ell t \tau$ ,  
Shearing resistance  $\tau = 0.8 \times 80$   
 $= 64$  [kgf/mm<sup>2</sup>]  
 $P = 3.14 \times 2.8 \times 1.2 \times 64 = 675$  kgf

## 2. Fracture of punch tip

### • Stress applied to punch tip $\sigma$ [kgf/mm<sup>2</sup>]

$$\sigma = P/A$$

P : Punching force, A : Cross-section area of punch tip

(a) For shoulder punch

$$\sigma_s = 4 t \tau / d \quad \dots \dots \dots (2)$$

(b) For jector punch

$$\sigma_j = 4 d t \tau / (d^2 - d_1^2) \quad \dots \dots \dots (3)$$

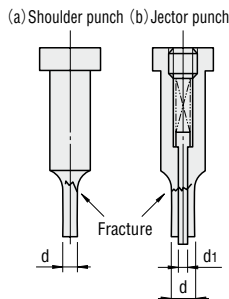

[Example 2] Find the possibility of punch tip fracture [Fig. 1] Fracture of punch tip when shoulder punch SPAS6—50—P2.8 and Jector punch SJAS6—50—P2.8 ( $d_1$  dimension=0.7, as shown on P. 186) are used. (Punching conditions are the same as in Example 1.)

(a) For the shoulder punch, from Formula (2):

$$\sigma_s = 4 \times 1.2 \times 64 / 2.8 = 110 \text{ kgf/mm}^2$$

(b) For the jector punch, from Formula (3):

$$\sigma_j = 4 \times 2.8 \times 1.2 \times 64 / (2.8^2 - 0.7^2) = 117 \text{ kgf/mm}^2$$

From Fig. 2, we see that when  $\sigma_s$  is 110 kgf/mm<sup>2</sup>, there is the possibility of fracture occurring with an SKD11 punch at approximately 9,000 shots.

When the material is changed to SKH51, this increases to approximately 40,000 shots.

The possibility for the jector punch is found in the same way. Because the cross-section area is smaller, the punch tip will fracture at approximately 5,000 shots.

Fracture will not occur if the stress applied to the punch during use is less than the maximum allowable stress for that punch material.

(Consider this to be only a guide however, because the actual value varies depending on variations in the die accuracy, die structure, and punched material, as well as the surface roughness, heat treatment, and other conditions of the punch.)

[Table 1] Shearing resistance and tensile strengths of various materials

M	Shearing resistance $\tau$ (kgf/mm <sup>2</sup> )		Tensile strength $\sigma_B$ (kgf/mm <sup>2</sup> )	
	Soft	Hard	Soft	Hard
Lead	2~3	—	2.5~4	—
Tin	3~4	—	4~5	—
Aluminum	7~11	13~16	8~12	17~22
Duralumin	22	38	26	48
Zinc	12	20	15	25
Copper	18~22	25~30	22~28	30~40
Brass	22~30	35~40	28~35	40~60
Bronze	32~40	40~60	40~50	50~75
Nickel silver	28~36	45~56	35~45	55~70
Silver	19	—	26	—
Hot rolled steel sheet (SPH1~8)	26 or more		28 or more	
Cold rolled steel sheet (SPC1~3)	26 or more		28 or more	
Steel sheet for deep drawing	30~35		28~32	
Steel sheet for building structures (SS330)	27~36		33~44	
Steel sheet for building structure (SS400)	33~42		41~52	
Steel 0.1% C	25	32	32	40
0.2% C	32	40	40	50
0.3% C	36	48	45	60
0.4% C	45	56	56	72
0.6% C	56	72	72	90
Steel 0.8% C	72	90	90	110
1.0% C	80	105	100	130
Silicon steel sheet	45	56	55	65
Stainless steel sheet	52	56	66~70	—
Nickel	25	—	44~50	57~63
Leather	0.6~0.8		—	
Mica 0.5 mm thick	8		—	
2 mm thick	5		—	
Fiber	9~18		—	
Birch wood	2		—	

\* (N) = kgf  $\times$  9.80665

(Schuler, Bliss)

[Fig. 2] Fatigue characteristics of tool steel

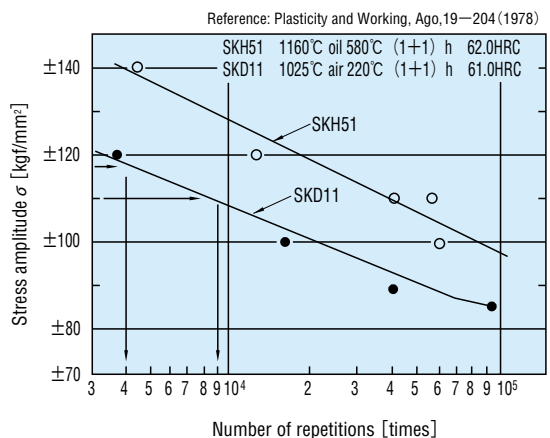

### 3. Minimum punching diameter

#### • Minimum punching diameter: $d_{min}$ .

$$d_{min} = 4t \tau / \sigma$$

$\sigma$ : Fatigue strength of tool steel [kgf/mm<sup>2</sup>]

[Example 3] The minimum punching diameter that is possible when punching 100,000 shots or more in SPCC of thickness 2 mm with an SKH51 punch is the following.

$$d_{min} = 4t \tau / \sigma \dots\dots\dots (4)$$

$$= 4 \times 2 \times 26 / 97$$

$$\doteq 2.1 \text{ mm}$$

Fatigue strength for SKH51 at 100,000 shots:

$$\sigma = 97 \text{ kgf/mm}^2 \text{ (from Fig. 2) } \tau$$

$$= 26 \text{ kgf/mm}^2 \text{ (from Table 1)}$$

[Fig. 3] Punching limit

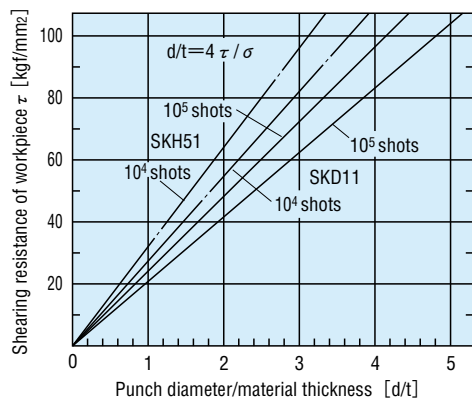

### 4. Fracture due to buckling

#### • Buckling load P [kgf]

$$P = n \pi^2 EI / \ell^2 \dots\dots\dots (5)$$

$$\ell = \sqrt{n \pi^2 EI / P} \dots\dots\dots (6)$$

$n$ : Coefficient  $n=1$ : Without stripper guide

$n=2$ : With stripper guide

$I$ : Second moment of inertia [mm<sup>4</sup>]

For a round punch,  $I = \pi d^4 / 64$

$\ell$ : Punch tip length [mm]

$E$ : Young's modulus [kgf/mm<sup>2</sup>]

SKD11	: 21000
SKH51	: 22000
HAP40	: 23000
V30	: 56000

As indicated by Euler's formula, steps which can be take to improve buckling strength P include the use of a stripper guide, the use of a material with a larger Young's modulus (SKD→SKH→HAP), and reducing the punch tip length.

The buckling load P indicates the load at the time when a punch buckles and fractures. When selecting a punch, it is therefore necessary to consider a safety factor of 3~5.

When selecting a punch for punching small holes, special attention must be paid to the buckling load and to the stress which is applied to the punch.

[Example 4] Calculate the full length of the punch which will not produce buckling when a  $\phi 8$  hole is punched in stainless steel SUS304 (sheet thickness 1 mm, tensile strength  $\sigma_b = 60 \text{ kgf/mm}^2$ ) with a straight punch (SKD11).

From Formula (6):  $\ell = \sqrt{n \pi^2 EI / P}$   
 $= \sqrt{2 \times \pi^2 \times 21000 \times 201 / 1206}$   
 $= 262 \text{ mm}$

If the safety factor is 3, then

$$\ell = 262 / 3 = 87 \text{ mm}$$

Punching force  $P = \pi d t \tau$   
 $= \pi \times 8 \times 1 \times 0.8 \times 60$   
 $= 1206 \text{ kgf}$   
 Second moment of inertia  $I = \frac{\pi d^4}{64} = \frac{\pi 8^4}{64}$   
 $= 201 \text{ mm}^4$   
 With stripper guide:  $n=2$

If the punch plate sheet thickness  $t$  is 20 mm, then buckling can be prevented by using a punch of total length 107 mm or less. For a punch based on the stripper plate (punch plate tip is guided by the clearance), the full length should be 87 mm or less.

[Example 5] The buckling load P when a SHAL5-60-P2.00-BC20 punch is used without a stripper guide is the following.

$$P = n \pi^2 EI / \ell^2$$

$$= 1 \times \pi^2 \times 22000 \times 0.785 / 20^2$$

$$= 426 \text{ kgf}$$

If the safety factor is 3, then

$$P = 426 / 3 = 142 \text{ kgf}$$

∴ Buckling will not occur at a punching force of 142 kgf or less.

Punch material: SKH51  
 $E = 22000 \text{ kgf/mm}^2$   
 $I = \frac{\pi d^4}{64} = \frac{\pi 2^4}{64}$   
 $= 0.785 \text{ mm}^4$   
 Without stripper guide:  $n=1$

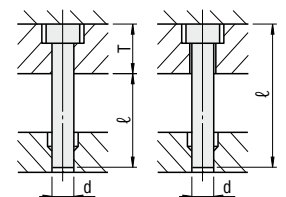

Based on punch plate    Based on stripper

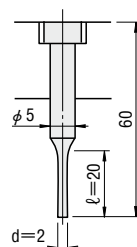

[Fig.4] Buckling of punch

■5. Flange fractures

As shown on P.1611, flange fractures are thought to be caused by tensile force generated by elastic waves which occur during punching (at breakthrough, tensile force equivalent to the punching load is applied to the punch), and by stress concentration.

Methods for preventing flange fractures include the following.

1. Increase the radius under the flange in order to relieve the concentration of stress. (Use a punch for heavy load.)
2. Increase the strength of the flange to a value higher than the punch tip.

Here we will use method 2 to find the optimum shank diameter that will not produce flange fractures.

●Finding the optimum shank diameter by calculation

Punching load P exerted on the punch is the following.

$$P = \pi dt \tau$$

The maximum allowable stress  $\sigma_w$  on the flange is the following.

- (a) For a shoulder punch,

$$\sigma_w = P \alpha / A_t \\ = 4P \alpha / \pi D^2$$

- (b) For a jector punch

$$\sigma_{wj} = 4P \alpha / \pi (D^2 - M^2)$$

Find the strength of the flange when the punching conditions are the same as in Example 1.

$A_t$ : Cross section area of flange [mm<sup>2</sup>]

- (a) For a shoulder punch,

$$A_t = \pi D^2 / 4$$

- (b) For a jector punch

$$A_t = \pi (D^2 - M^2) / 4$$

D: Shank diameter

$\alpha$ : Coefficient of stress concentration

- (a) For a shoulder punch,  $\alpha \cong 3$

For a punch for heavy load,  $\alpha \cong 2$

For tapered head punch,  $\alpha \cong 1.6$

- (b) For a jector punch,  $\alpha \cong 5$

[Fig. 5] Flange fracture

- (a) Shoulder punch (b) Jector punch

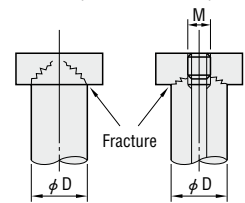

- [Example 6] (a) In the case of shoulder punch SPAS6—50—P2.8 :

$$\sigma_w = 4 \times 675 \times 3 / \pi \cdot 6^2 = 71.6 \text{ kgf/mm}^2 \dots \dots \dots \text{Flange fracture will not occur because the stress is less than the stress applied to the punch tip in Example 2 of } 110 \text{ kgf/mm}^2.$$

- (b) In the case of jector punch SJAS6—50—P2.8 :

$$\sigma_{wj} = 4 \times 675 \times 5 / \pi (6^2 - 3^2) = 159 \text{ kgf/mm}^2 \dots \dots \dots \text{Fracture occurs from the flange because the stress is larger than the stress applied to the punch tip in Example 2 of } 117 \text{ kgf/mm}^2.$$

When the shank diameter is 8mm,  $\sigma_{wj} = 90 \text{ kgf/mm}^2$ , which does not cause flange fractures. (Considering from the figure showing the fatigue strength of tool steel, the flange will break after about 50,000 shots.)

●Finding the optimal shank diameter from the diagram

Punching conditions : Use the following formula to convert punch tip  $P=12.8$   $W=10.6$  to a  $\phi d$  value.

$$\phi d = [2(P-W) + W \pi] / \pi \\ = [2(12.8 - 0.6) + 10.6 \pi] / \pi \\ = 12 \text{ mm}$$

Sheet thickness  $t=4$  mm Shearing resistance  $\tau = 50$  kgf/mm<sup>2</sup>

In order to find the optimal shank diameter for 10<sup>4</sup> shots, follow the steps below.

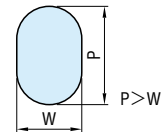

**Durability of punch tip (fracture)** [Fig. 6]

- a) Find the point a where the sheet thickness t and shearing resistance  $\tau$  intersect.
- b) Find point b by extending a line to the left or right from point a until it intersects the diameter of the punch tip.
  - Because Point b is below the line indicating 10<sup>5</sup> shots, both SKH and SKD punches will be capable of enduring a minimum of 10<sup>5</sup> shots.

**Selection of shank diameter** [Fig. 7]

- c) Find Point c by extending a line to the right from Point a until it intersects the punch tip diameter.
- d) Find Points d and d' by extending a line down from Point c until it intersects the lines indicating 10<sup>4</sup> shots (line for standard, line for thick sheets).
- e) Find the shank diameter by extending lines to the right from Points d and d'.
  - Because 14.0 is indicated for standard punches (SKH), select a shank diameter of  $\phi 16$ .
  - Because 11.8 is indicated for punches for heavy load (SKH), select a shank diameter of  $\phi 13$ .

Note: This selection table was prepared based on the results of tensile and compression fatigue tests. Because the data may differ somewhat from the actual punching conditions, please use this table only as an approximate guide.

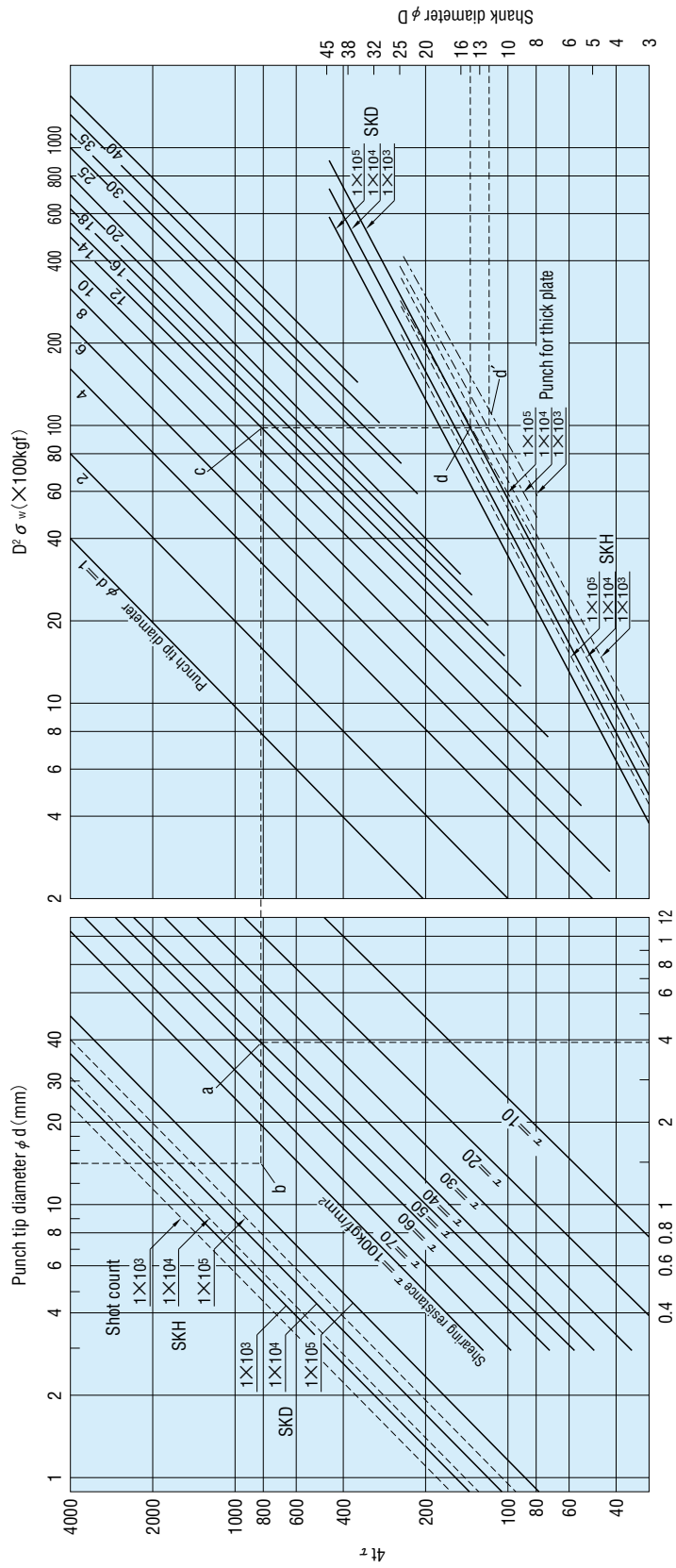

— SKD11  
 - - - SKH51  
 - - - Punch for thick plate

[Fig. 7] Selection of shank diameter

Material thickness  $t$  (mm)

[Fig. 6] Durability of punch tip (fracture)

# [PRODUCTS DATA] DURABILITY OF PUNCHES

Characteristics required of punching tools include wear resistance, compression resistance, and toughness. Although the use of powdered high-speed steel and a variety of surface treatments have significantly lengthened the life spans of tools, it is still necessary to choose proper tools according to the punching conditions.

As data for this purpose, provided below are the results from tests of punching life spans, buckling, and transverse rupture on punches which utilize SKD11, SKH51, or HAP40 (powdered high-speed steel) materials in combination with TD treatment.

Note: TD=DICOAT® punch (Refer to P.1599.)

## ■ 1. Punching life span

### ● Punching conditions

Workpiece material : S55C    Sheet thickness : 1.0 mm  
 Punch diameter : 8.0 mm    Clearance : 10%  
 Die material : SKD11    Lubrication : No lubrication  
 Bridge width : 1.5 mm    Press used : 25—Ton  
 Punching speed : 200 SPM

### ● Test results

#### — Side wear —

Figure 1 shows the changes in the surface area of side wear with increasing numbers of punching shots.

- (1) The amount of punch side wear decreases according to material in the following order: SKD11, SKH51, HAP40, SKD—TD, HAP—TD.
- (2) Because the TD treated punch has high surface hardness (3000 HV or higher), it shows figures for side wear that are extremely low.

#### — Height of burrs —

Figure 2 shows the changes in burr height with increasing numbers of punch shots.

- (1) The punch life span increases according to material in the following order: SKD11, SKH51, SKD—TD, HAP40, HAP—TD. When the burr height reached 50  $\mu\text{m}$ , it was judged that the punch life span had been reached. However the HAP—TD punch reached 500,000 punching shots and had not yet reached the end of its life span. The TD process coats the punch with VC (vanadium carbide) in order to enhance its wear and seizure resistance. The long life span of this punch is due to the very small amount of side wear on the HAP—TD punch and also to the small amount of end wear owing to the HAP 40 (65 HRC) base material.

[Table 1] Types of tools used

Material and surface treatment	Hardness (HRC)	Primary chemical components (%)				
		C	Mo	W	V	Co
SKD11	61	1.5	1.0	—	0.3	—
SKD—TD	60					
SKH51	61	0.9	5.0	6.0	2.0	—
HAP40	65	1.3	5.0	6.5	3.0	8.0
HAP—TD	62					



[Fig. 1] Changes in area of side wear

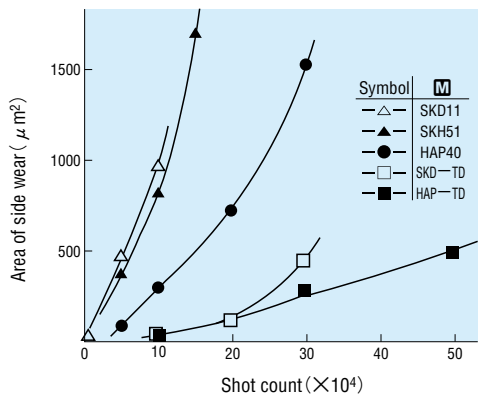

[Fig. 2] Changes in height of burr with increasing shot count

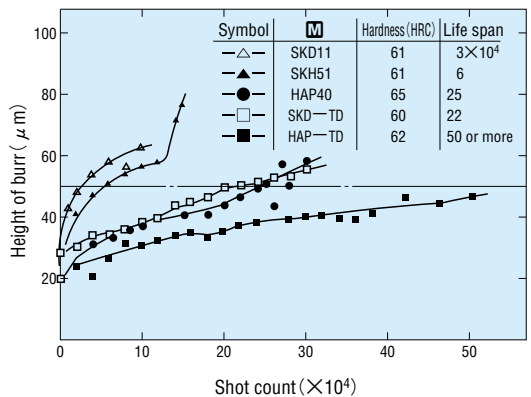

## 2. Buckling and traverse rupture tests

### ● Test conditions

As shown in Figure 3, find the maximum load before fracture occurs when the buckling load and transverse rupture load (applied using a knife-edge shape indenter at a point 0.5 mm from the punch tip end) are applied at a speed of 1 mm/min.

### ● Test results

As shown in Table 2, both the buckling and transverse rupture forces increased in the following order of materials: SKD11, SKD51, HAP40. HAP40 in particular is able to maintain high hardness and thus displays excellent compression resistance. In addition, because its metallic structure is extremely fine and contains high alloying components (such as W, V, and Co), HAP40 also has excellent toughness. Therefore, the HAP40 punch is most suitable for punching where there is concern of fracture or chipping occurring.

Since the TD treated punches have lower base material hardness, the buckling strength and transverse rupture strength are also somewhat lower.

[Fig. 3] Buckling and traverse rupture tests

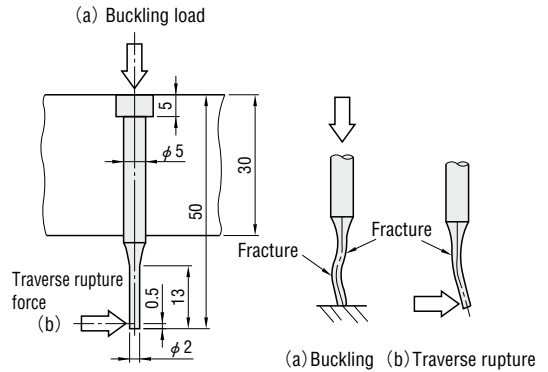

[Table 2] Results of buckling and transverse rupture tests

Material and surface treatment	Buckling				Transverse rupture			
	Hardness (HRC)	Buckling load [kgf]	Buckling strength [kgf/mm <sup>2</sup> ]	Proportion [%]	Hardness (HRC)	Transverse rupture force [kgf]	Fracture deflection [mm]	Proportion [%]
SKD11	61.1	805	265	100	60.5	21.4	2.28	100
SKD—TD	59.6	829	264	103	59.5	19.4	1.65	91
SKH51	61.5	946	301	118	61.8	26.8	2.37	125
HAP40	66.0	1168	372	145	64.8	29.8	2.37	139
HAP—TD	62.2	952	303	118	62.0	24.5	1.75	113

\* (N) = kgf × 9.80665

## 3. Conclusion

Below are the toughness, transverse rupture strength, and wear resistance for each material, relative to the performance of SKD11.

- (1) SKH51 has 120% the buckling and transverse rupture resistance, and 200% the wear resistance of SKD11.
- (2) SKD—TD has equal buckling resistance, 90% the transverse rupture resistance, and 700% the wear resistance of SKD11.
- (3) HAP40 has 150% the buckling resistance and 140% the transverse rupture resistance, and 800% the wear resistance of SKD11.
- (4) HAP—TD has 120% the buckling resistance, 110% the transverse rupture resistance, and 1600% the wear resistance of SKD11.

### ● Economy of punches

Figure 4 illustrates the punching life spans, cost, and cost/life-span ratios for punching of S55C. With the cost performance of SKD11 punches taken as 1, the expected cost performance for SKH51 is 1.5, for SKD—TD is 2.0, for HAP40 is 3.5, and for HAP—TD is 3.2.

This data is taken from life span tests performed with S55C, and may differ somewhat when other materials are used for punching.

[Fig. 4] Comparison of economy of punches

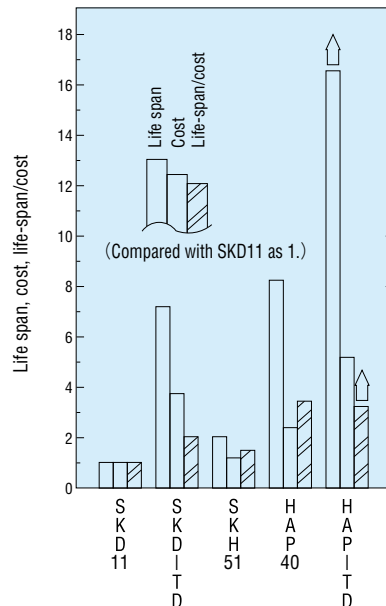

**DICOAT® Punches**

DICOAT® punches are revolutionary standard punches that have superior properties made possible by a vanadium carbide layer produced by the TD process. With a surface hardness of 3200~3800 HV, these punches are not only effective as wear resistant and seizure resistant punches, but also can deliver reductions in total costs. Thanks to the license for “TD process treatment and sales for die standard parts” granted to MISUMI by Toyota Central R&D Labs, Inc., MISUMI has succeeded in creating an integrated process from punch production to TD process treatment for DICOAT® punches which ensures the same dimensional accuracy as with conventional punches. The TD process is a process of “surface hardening by diffusion” that was developed by Toyota Central R&D Labs, Inc., an organization which acts as the general research institute for the Toyota Group. With this method, certain elements (carbides) are diffused to penetrate the metal and form a surface layer with superior wear resistance and seizure resistance. This method was first commercialized in 1970, and since that time has been widely used to improve the performance of press dies, cold forging steel dies, casting dies, and other dies, as well as blades, jigs, and machine parts.

[Fig. 1] DICOAT® punch cross section structure

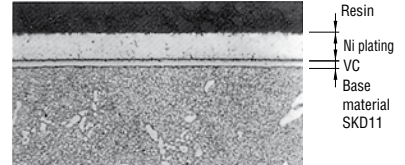

**Features of DICOAT® punches**

**1. Wear resistance: Surface hardness**

- The tip of a DICOAT® punch is coated with a 4~7 μm vanadium carbide (VC) film.
- VC is extremely hard (3200~3800 HV), demonstrating superior wear resistance when punching all types of materials.

**2. Resistance to seizure and abrasion**

- DICOAT® punches demonstrate superior wear resistance when used with all types of materials. These punches have an excellent product surface that is resistant to scratching.

[Fig. 2] Comparison on surface layer hardness

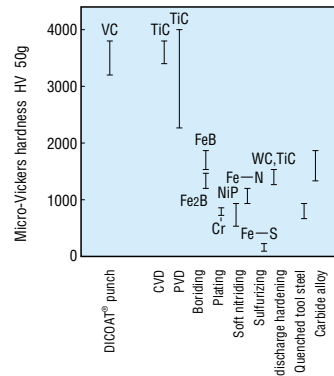

[Fig. 3] Comparison of wear resistance and seizure resistance in press-thinning process

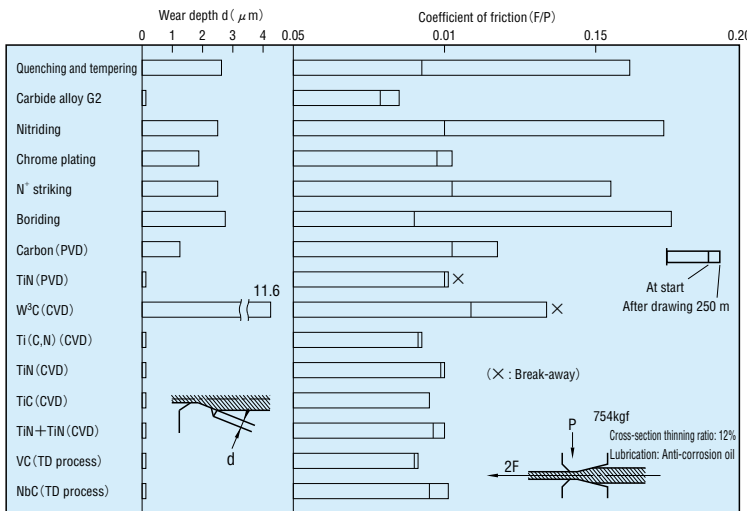

[Fig. 4] Cross-section structure of punch tip after use

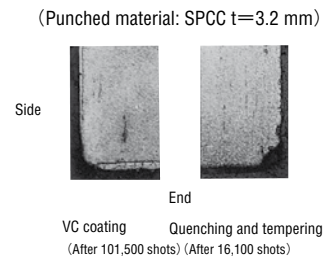

### 3. Toughness

- VC coating does not decrease the toughness of the base metal. In addition, because DICOAT® punches are tempered at high temperatures, they have high toughness and feature lower risk of breakage compared with ordinary punches.

[Fig. 5] Comparison of traverse rupture force

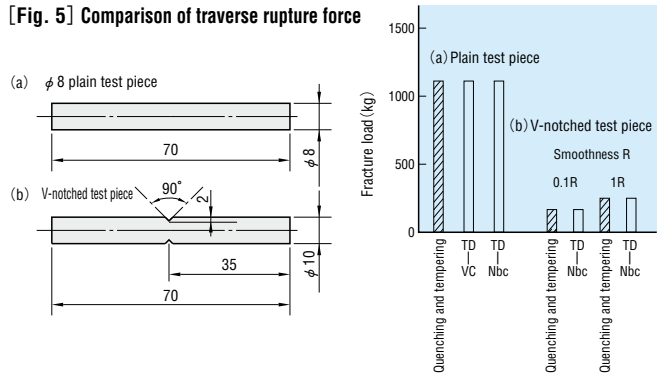

### Advantages of DICOAT® punches

#### 1. DICOAT® punches exhibit excellent wear and seizure resistance under a wide range of service conditions.

DICOAT® punches offer other advantages in addition to improved life spans, particularly in the following circumstances.

- Cases in which ordinary punches experience severe wear, and required a large amount of regrinding  
Because the amount of necessary regrinding is small, the required regrinding time is short. This raises the number of possible regrinds before the punch is scrapped, increasing the total number of punches which the punch can complete in its lifetime.
- Cases in which quality control is carried out based on burr height  
Because the speed at which burr height increases is low, quality control based on burr height can be accomplished with minimal man-hours.
- Cases when the product surface is a major concern  
Because scratching rarely occurs, stable production of products with high surface quality is possible.
- Cases when a lubricant with poor workability or a highly expensive lubricant is used. Because scratching is unlikely and wear is low, the lubricant requirements are not strict. Moreover, it is possible to reduce the overall amount of lubricant used.

#### 2. Stock materials that can be used with a DICOAT® punch

Steels	SS, SPC, SPH, SC, SCM, SK, SUS, high tensile-strength steels, silicon steels, others
Surface-treated steel sheets	Sn plated steels, Zn plated steels, aluminized steels, plastic-coated steels
Nonferrous metals	Al, Al alloys, Cu, Cu alloys, Zn alloys, Ni alloys, others
Non-metal materials	Rubber, fabric-reinforced rubber, fabric-reinforced bakelite, others

#### 3. Reduction in man-hours required for die repair

Figure 6 shows the results from an investigation conducted at Company B of the relationship between the time required for repair of progressive dies and the effects of the TD process.

The time required for repair shown here includes all repair time including the time required for regrinding of bending and blanking punches, and for incidents resulting from operator error.

Although the use of TD parts for these progressive dies was limited to bending punches and dies, a close relationship is clearly evident between the start of TD process use and the required repair time. Before the use of the TD process, the repair time per 100,000 units produced was 50 hours, a figure which was reduced to 15 hours after the introduction of the TD process. The benefit to Company B was thought to be considerable, considering its large production volume.

[Fig. 6] Changes in die repair index by TD treatment

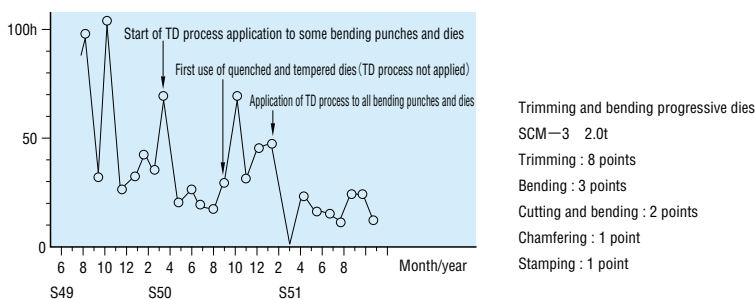

Introduction

In recent years, there has been growing use of high-tensile steel sheet in the automobile industry due to increasing worldwide demands for weight reduction and higher safety performance. The punching conditions for high-tensile steel sheet become increasingly severe year after year, leading to problems of early wear and chipping. Consequently, there is much interest in increasing the life spans of the punches. So-called "coating punches" with improved coating adherence and wear resistance have been commercialized in order to solve these problems. These improved coating punches have much longer life spans than conventional products.

Features of improved coating punches

Better adhesion of the coating film

Unless the coating film adheres strongly to the base material, the film will quickly separate due to external stress despite its excellent coating properties. Accordingly, in order to evaluate the adhesion force of the film, indentation tests using a Rockwell hardness tester (C scale) were performed, and the conditions of film separation were observed. The tests showed that while coating separation and cracking occurred in the conventional product, separation did not occur in the improved product, demonstrating the improved adhesion of the coating film. (Fig. 1)

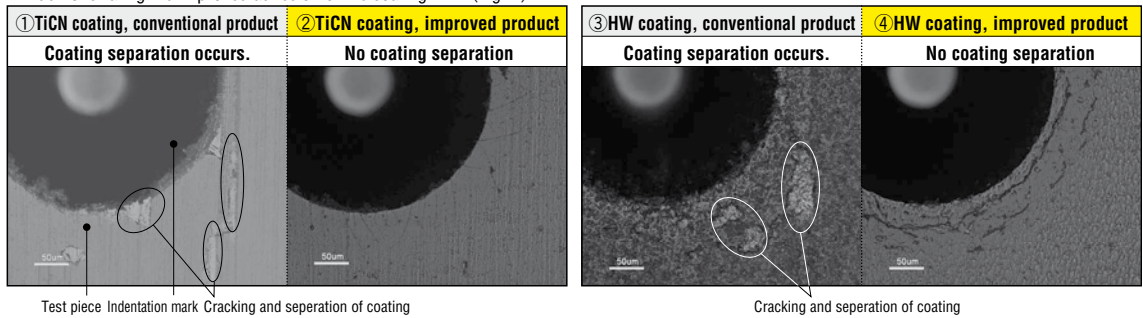

(Fig. 1) Results of observation after indentation test (test piece material: SKH51)

Improved wear resistance

One cause of punch wear is adhesive wear in which the workpiece and punch stick together, causing wear of both parts. In order to evaluate the wear resistance, a friction wear test was carried out and the relative wear of the ball was measured. Here, the test piece (base plate) simulates the punch and the ball simulates the workpiece (Fig. 2), and the relative wear of the ball was measured in order to determine the superiority or inferiority of the wear resistance. Compared to the conventional product, ball relative wear fell by approximately 26% when a TiCN coating was used, and by approximately 60% when an HW coating was used. (Fig. 3) This test also shows that the improved product ball has a smaller friction surface (Fig. 4) and better wear resistance than the conventional product.

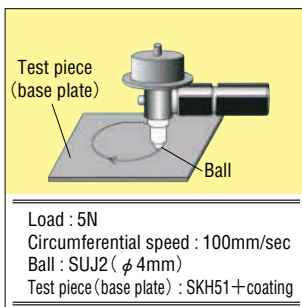

(Fig. 2) Overview of friction wear test

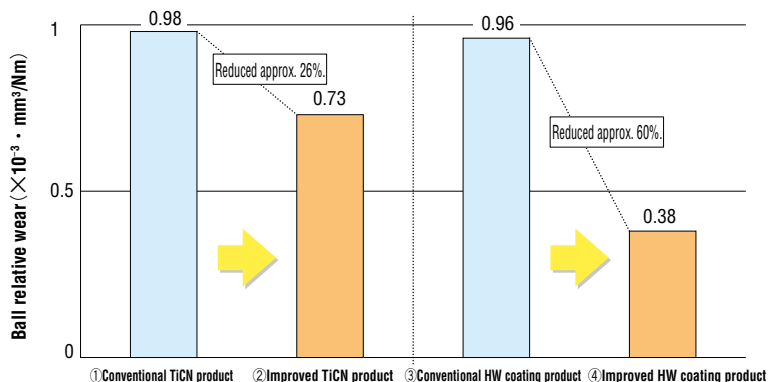

(Fig. 3) Relative wear of ball after friction wear test

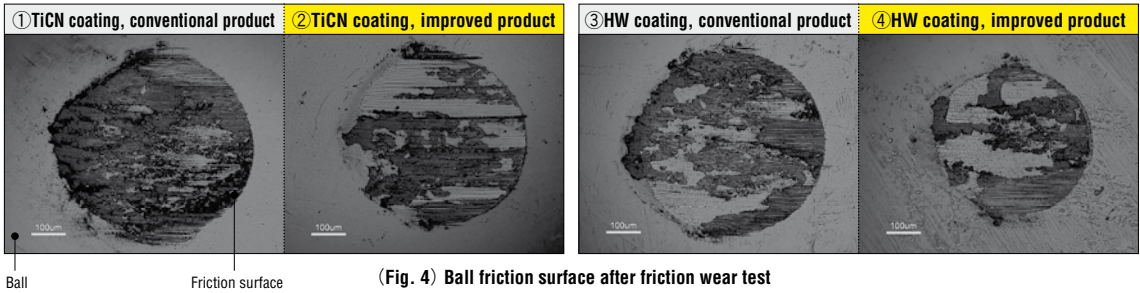

(Fig. 4) Ball friction surface after friction wear test

### Punching life span test with 980 MPa high-tensile steel

A punching life span test using 980 MPa high-tensile steel was carried out, and the burr height of the punching scrap was measured (Fig. 5). (Test conditions: Table 1)

If the maximum allowable burr height is assumed to be 50 µm, the improved TiCN coating product can be used for a minimum of 1.5 times the number of shots as the conventional product.

A comparison of the burr height after 400,000 shots shows that the improved HW coating product produces scrap with the smallest burr height, and also that this punch has the highest durability of the coating punches used in this punching test.

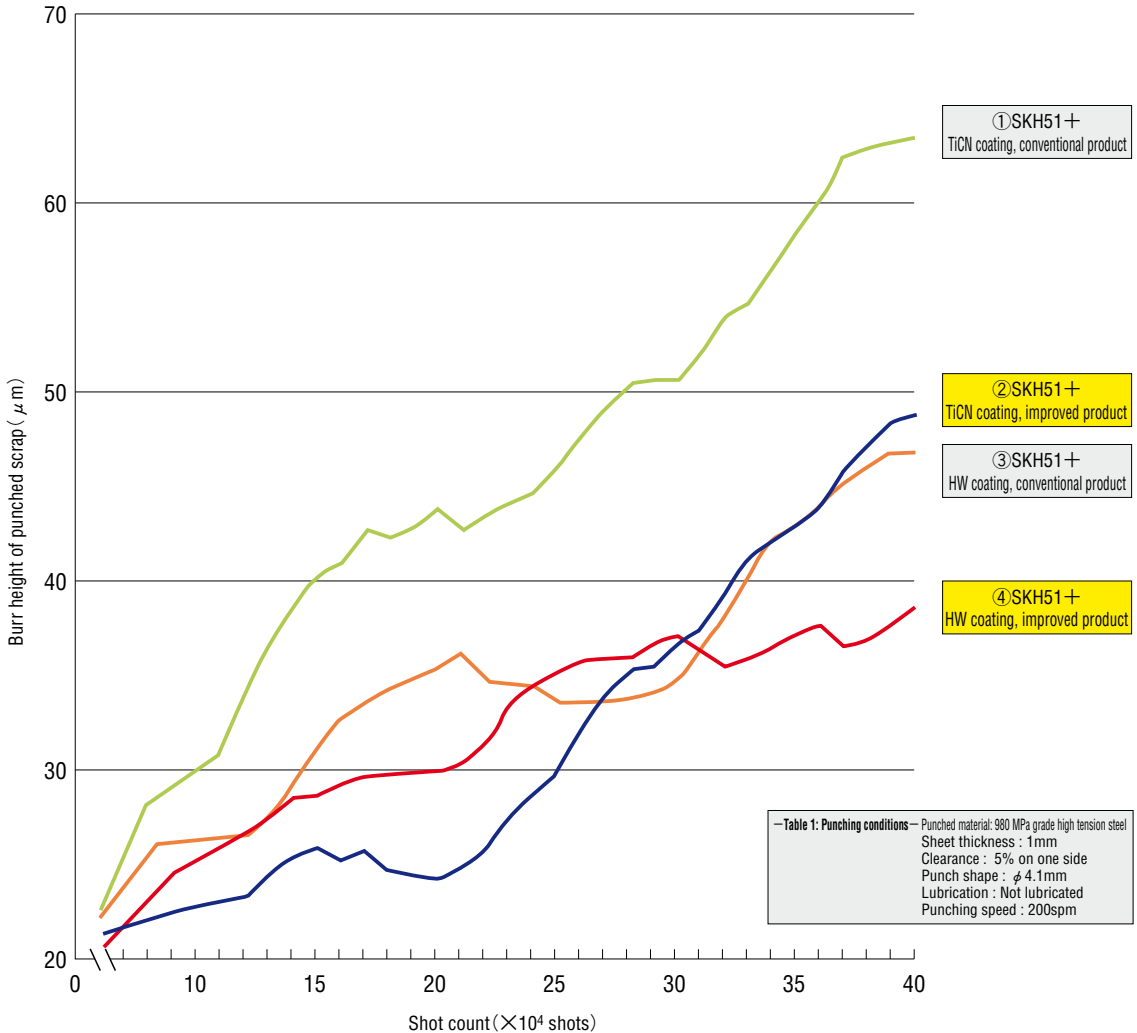

(Fig. 5) Changes in burr height with increasing shot count

■ Comparison of tip and side appearance at a punching life span test using 980 MPa high-tensile steel

When the appearance of the tips was compared after a punching test (400,000 shots) using 980 MPa high-tensile steel (Fig. 6), separation of the coating film and seizure were found on the tip of the conventional product. Also, there was chipping and wear of the edges over a broad area. On the other hand, while separation of the film that was thought to be the result of edge chipping was found on the improved TiCN coating product, no seizure was found on the tip or side, and the tip remained in generally good condition after the test. No chipping or seizure at all was observed on the improved HW coating product, demonstrating that good coating film conditions were maintained. It is believed that the WPC® treatment contributes to improved fatigue strength of the punch tip. (※For details concerning the WPC® treatment, refer to P. 1605.)

From the above results, it was confirmed that the improved product is highly effective even with materials that are difficult to machine, such as 980 MPa high-tensile steel.

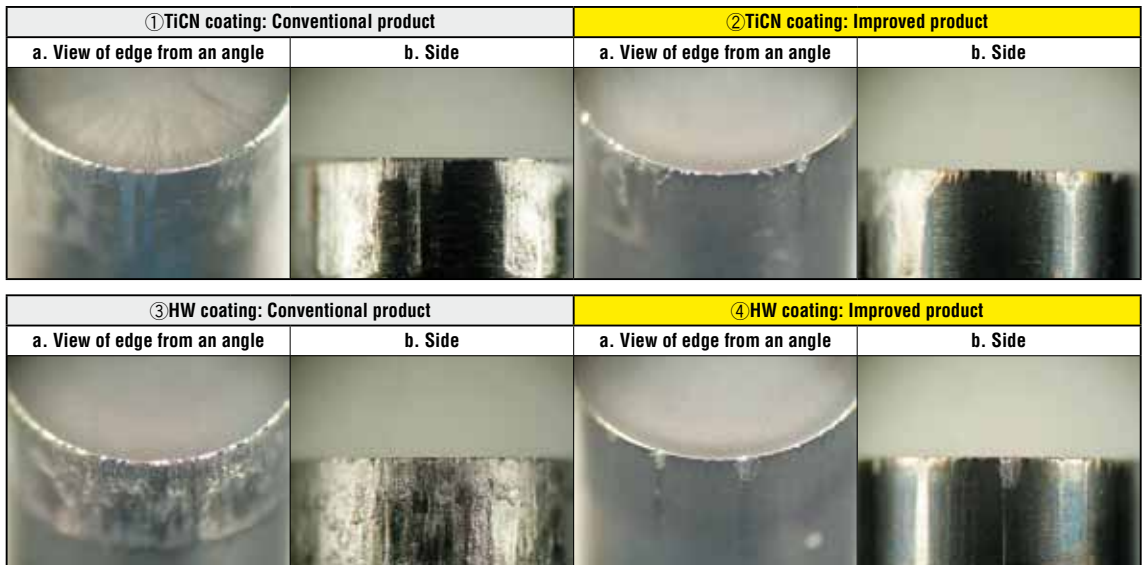

(Fig. 6) Appearance of the tip after the punching life span test (400,000 shots) using 980 MPa high-tensile steel

Reference: List of punches for which improved coating products are available

Improved punch	M	TiCN coating: Improved product	HW coating: Improved product	Improved punch	M	TiCN coating: Improved product	HW coating: Improved product
Shoulder punch	SKH51	●	●	Punch for heavy load	SKH51	●	●
	Powdered high-speed steel	●	●		Powdered high-speed steel	●	●
Jector punch	Powdered high-speed steel	●	●	Jector punch for heavy load	Powdered high-speed steel	●	●
Jector punch (spring-reinforced type)	Powdered high-speed steel	●	●	Jector punch for heavy load (fixed B type)	Powdered high-speed steel	●	●
Shoulder quill punch	SKH51	●	/	Tapered head punch	SKH51	●	●
	Powdered high-speed steel	●			Powdered high-speed steel	●	●
Shoulder short punch	SKH51	●	/	Tapered head jector punch	SKH51	●	●
	Powdered high-speed steel	●			Powdered high-speed steel	●	●
Key flat shank shoulder punch	SKH51	●	●	Punch for heavy load with dowel hole	SKH51	●	●
	Powdered high-speed steel	●	●		Powdered high-speed steel	●	●
Key flat shank jector punch	Powdered high-speed steel	●	●	Jector punch for heavy load with dowel hole	SKH51	●	●
Key flat shank jector punch (spring-reinforced type)	Powdered high-speed steel	●	●	Tapped punch	SKH51	●	●
Punch with locating dowel hole	Equivalent to SKD11	●	●		Powdered high-speed steel	●	●
	Jector punch with locating dowel hole	Equivalent to SKD11	●	●	Punch with key groove	SKH51	●
Jector punch with locating dowel hole (spring-reinforced type)	Equivalent to SKD11	●	●	Powdered high-speed steel		●	●
Straight punch	SKH51	●	/	Straight punch	SKH51	●	●
	Powdered high-speed steel	●			Powdered high-speed steel	●	●

※The above punching test used an ISIS 20-ton precision press and precision progressive dies. With actual dies, because a broad range of factors including press accuracy and variation in clearance accuracy are involved, it is expected that wear will occur earlier than in this punching test. Please use the results here as reference data.

## ■ Coating punches — TiCN —

MISUMI's coating punches receive a TiCN coating applied by ion plating, which is one type of PVD (physical vapor deposition). TiCN coating has a number of advantages, including high hardness and low friction coefficient. It improves punch wear resistance, contributing to higher productivity and improved product quality. Because these punches are treated in high vacuum at temperatures of 500°C, coating of base materials tempered at temperatures of 500°C or higher can be achieved with no loss of base material hardness and no thermal deformation. This ensures that the tip remains sharp after coating, which is one of the large advantages of this method.

Because the dimensions and accuracy of MISUMI coating punches after coating are guaranteed, there is no need to control dimensions in consideration of the coating thickness.

Technical data of TiCN coating

Hardness (HV)	3000
Coating thickness (μm)	2~4
Friction coefficient (with steel, when dry)	0.3
Heat resistance (°C)	~400
Color	Blue gray

## ■ Features of TiCN coating punches

### 1. High hardness

TiCN coating has a hardness of 3000HV, which is harder than carbide. This high hardness provides the cutting edges with good protection from wear, extending the life span before regrinding by up to 10 times.

### 2. Small friction coefficient

TiCN coating has a small coefficient of friction with steel, and is chemically inert. This makes it possible to avoid the surface fatigue that leads to cracking. This coating treatment keeps the punch surface away from the workpiece surface, therefore even after the cutting fluid has lost its chemical activity, it still provides lubricating effects. Also TiCN has superior sliding characteristic, allowing pressing with high-speed strokes. Greater benefits can be expected from TiCN coating punches with workpieces that have a strong tendency toward sticking (such as light metals, nonferrous metals, and stainless steel).

### 3. Product quality improvements

TiCN makes it possible to produce products with little burring and with long punch life spans, and to deliver smooth cut surfaces with few streaks.

## ■ Notes concerning the use of TiCN coating punches

Please pay attention to the following when using a TiCN coating punch.

- The effective coating punch range (length) is B dimension (tip length), however an extremely thin and incomplete coating of 0.5 μm or less is also formed for approximately 10 mm beyond this range.
- Slight variation occurs in the thickness of the coating film at the corners of the tip shape.
- When regrinding, avoid strong grinding in order to prevent separation of the coating layer.

■ **Features of WPC®-treated punches**

**1. Improved fatigue strength**

WPC® treatment involves colliding fine particles approximately 0.04~0.2 mm in size with the metal surface at speeds of 100 m/s or more, generating high residual compressive stress in the area close to the surface of the punch (Fig. 1). This improves the fatigue strength of the punch, yielding a high resistance to tip breakage and chipping (Fig. 2). Fig. 2 shows an example. When a load of 1,200 N/mm<sup>2</sup> is repeatedly applied to the tip, the possibility of breakage occurs at approximately 10,000 strokes with SKD11, however with SKD11+WPC® treatment, the number of strokes rises to approximately 100,000. (Because the results shown in Fig. 2 differ from those of an actual punching test, use them only as an approximate guide.)

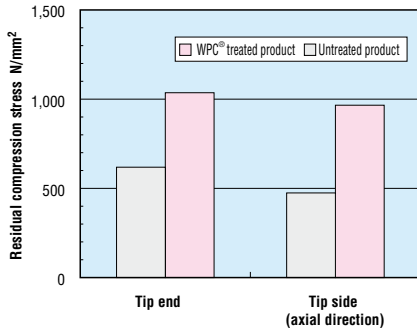

[Fig. 1] Surface residual compression stress due to WPC® treatment  
Punch material: SKD11

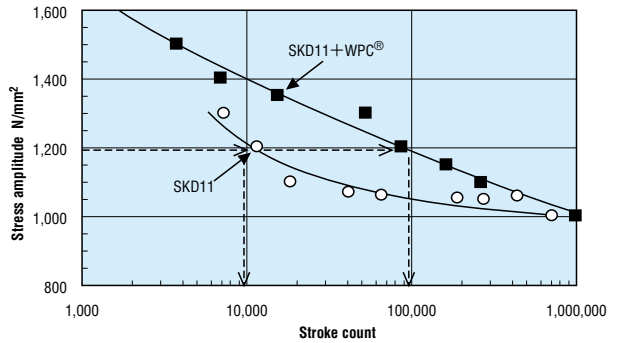

[Fig. 2] Improvement in fatigue strength due to WPC® treatment  
Load conditions: Pulsating load, test piece: φ 4.61 HRC

**2. Improved seizure resistance**

In the case of an ordinary polished finish, streaks in the direction of the polishing are left on the surface. In contrast, fine convex and concave surface irregularities are formed on a surface that is treated with WPC® (Fig. 3). Because the minute concave portions serve to trap oil, a WPC®-treated surface is more resistant to losing its oil film than an ordinary polished surface, improving its resistance to seizure.

**3. Improved wear resistance**

The WPC® treatment improves surface hardness through the effects of work hardening, improving the wear resistance of the punch. Because the hardness of a WPC®-treated punch gradually increases moving from the inside of the punch toward the surface (Fig. 4), there is no loss of toughness in the punch base material.

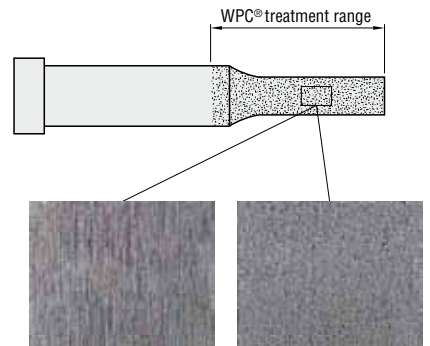

[Fig. 3] Surface comparison of normal polished product and WPC® treated product

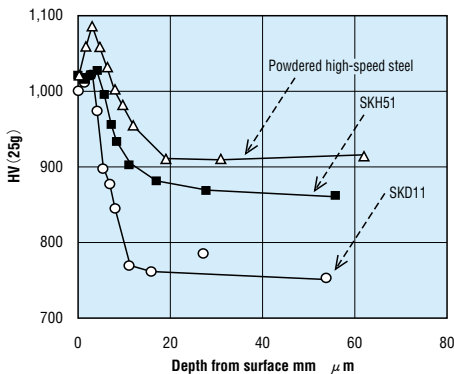

[Fig. 4] Hardness distribution near the surface of a WPC® treated product  
Measured using a micro-Vickers hardness tester.

## ■ Features of HW coating

With conventional TiCN treatment, there was the problem of coating separation that sometimes occurred under conditions when high stress was applied to the punch. It is thought that this problem occurred when a punch base material of relatively low hardness was deformed, and the very hard coating film was unable to follow this deformation. With the HW coating, the base material of the punch is strengthened by WPC® treatment, improving the adhesive performance of the TiCN film. The HW coating is a new kind of surface treatment which combines the excellent wear resistance of the TiCN coating with the inherent high fatigue strength of the WPC® treatment.

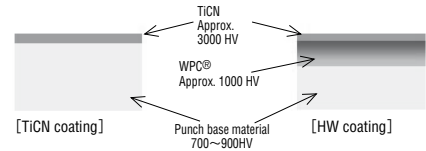

[Fig. 5] Models of HW coating and TiCN coating

## [Reference Data] Punching life span test using conventional products

### ■ SUS304 punching life span test

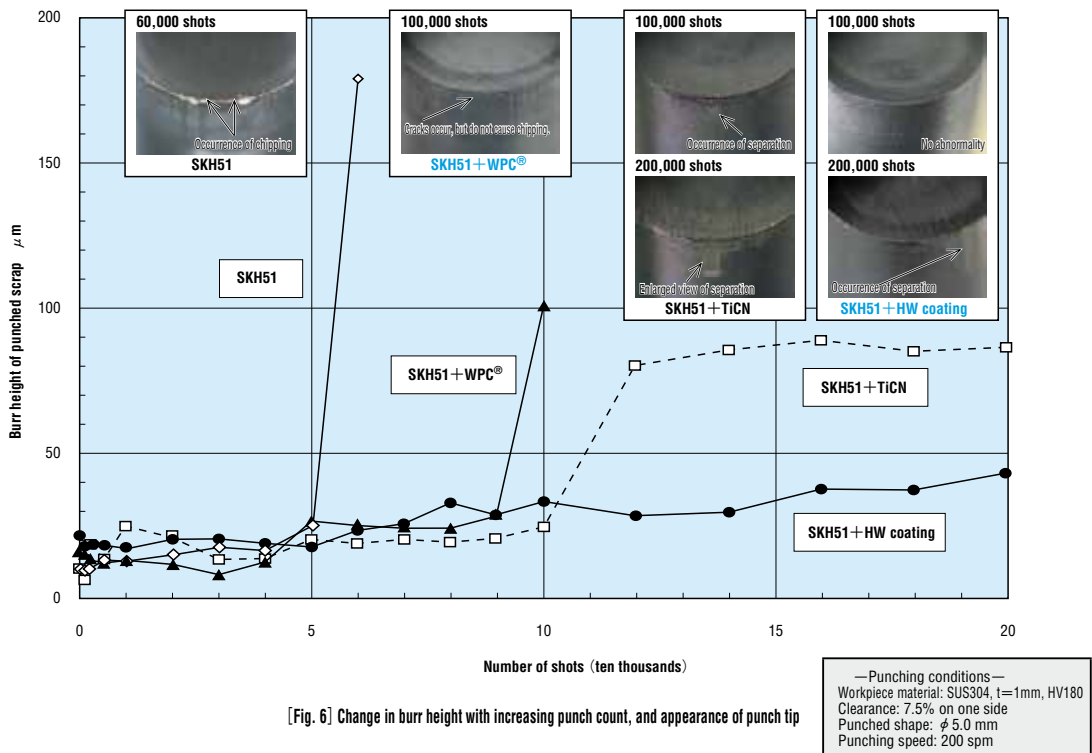

[Fig. 6] Change in burr height with increasing punch count, and appearance of punch tip

If the maximum allowable burr height is assumed to be 100  $\mu\text{m}$ , a WPC®-treated punch is capable of nearly double the number of punch shots as an untreated punch. In addition, it was also found that whereas an untreated punch started to chip at the edges of the tip at 60,000 shots, the punch treated with WPC® showed no significant chipping even at 100,000 shots. These results confirm the improvement in punch tip fatigue strength resulting from the WPC® treatment.

Both the TiCN coating punch and the HW coating punch were able to withstand a minimum of 200,000 punching shots. However when the two punch tips are compared, we find that while coating film separation and an increase in burr height began at 100,000 shots with the ordinary TiCN coating punch, with the HW coating punch, there was absolutely no separation at 100,000 shots and the burr height remained at a low level up to 200,000 shots. These results confirmed that the HW-coated punch exhibits superior performance even when used on difficult-to-machine materials such as SUS304.

**Overview**

The MISUMI “HW coating” has been widely used by a large number of customers in the automobile industry and has received favorable reviews. However, more rigorous press forging is being carried out for high tensile strength steel sheets and thick plate high tensile steel sheets in recent years. It is not uncommon to see premature wear and tear, or peeling off of the coating in the conventional products that have been manufactured so far, and so several requests have been received from customers to extend the durability of the punch. The MISUMI “RW coating” offers superior abrasive resistance and adhesive capability compared to its predecessors and its competitors, and also offers significantly improved punch life.

**Features**

**1) Enhanced abrasive resistance**

The RW coating is a composite coating that undergoes the WPC® treatment at the base of the coating, and is lined with a layer of AL-Cr type coating at the top. It has a hardness degree as high as 3,100 HV. Since it is much harder than its predecessors, it is ideal for customers who have been facing problems with premature wear and tear of the punch cutting edge.

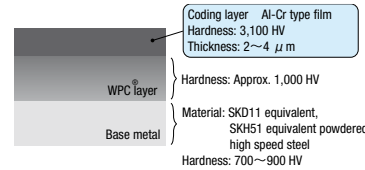

[Fig 1] Cross-sectional view of the RW coating structural model

**2) Improved peeling resistance**

The Rockwell presser was used to rapidly deform the plastic in the base material of the punch, and the adhesive capability and crack resistance of the film was evaluated [Fig 1]. In the case of the HW coating, the TiCN film could not withstand the bulging in the base layer of the punch, and numerous cracks appeared around the Rockwell impression. On the other hand, with the RW coating, the film was able to withstand the deformation of the base layer of the punch and no cracks were observed. It is a superior coating that achieves a balance between both the hardness and the improved adhesive capability of the film.

[Fig 1] Evaluation of adhesive capability of the film through Rockwell impression test

Test load : 150 kgf  
Punch base material : Powdered high speed steel

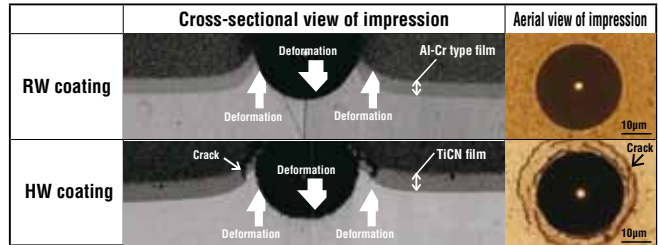

**3) Improved heat and temperature resistance**

A heat and temperature resistance test was conducted for the steel that was subjected to RW coating and HW coating, and the structural observation of the film's cross-section was done. [Fig 2] We can see that when the HW coating was held in 1000 degrees for 5 minutes, the Ti of the film was changed to coarse oxide. Contrarily, when the RW coating was held in 1000 degrees for 540 minutes, it retained its fine structure, and thus, we were able to confirm that it has superior heat resistance. The heat resistance (Oxidation temperature) of the RW coating and other various kinds of coating has been summarized in [Fig 3]. Therefore, it is evident that the RW coating is a coating variety that offers superior hardness and heat resistance.

In rigorous pressing treatment of high tensile strength steel sheets or thick plate high tensile strength sheets, the temperature of the cutting edge of the punch will rise steadily. Though it also depends on the cooling conditions of the cutting edge of the punch achieved through press shearing speed and press treatment oil, there is research to prove that the temperature could momentarily go up to as high as 600 degrees. When faced with premature wearing off of the coating, it could be possible that the increase in temperature of the punch cutting edge causes the coating to peel off, and so the use of the RW coating is recommended as it offers superior resistance to high temperatures.

**Maintenance of its fine structure**

**Creation of coarse oxide**

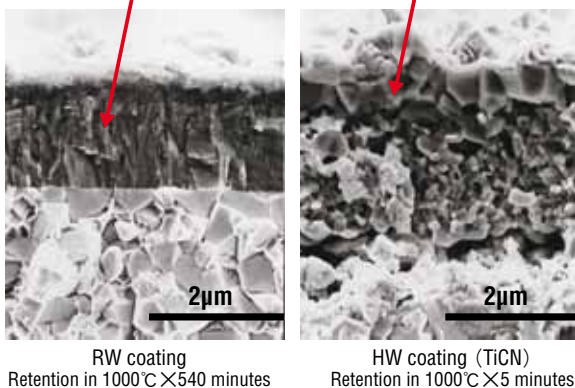

[Fig 2] Heat Test Cross-sectional structure observation

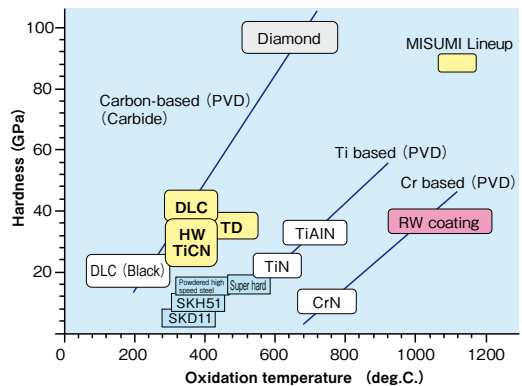

[Fig 3] Relationship between film hardness and heat resistance (Image)

※Points to be noted The heat resistance temperature shown in this report is the heat resistance temperature of the coating film alone and does not take into account the tempering temperature of the punch base material. In case it is used in a pressing environment where the temperature does not increase momentarily just in the punch surface, but the temperature of the entire mold or punch rises above the tempering temperature of the punch base material, the base material of the punch will be annealed, and there is a risk of reduction in hardness.

## Thick plate high tensile strength steel sheet 590 MPa Thickness 10 mm Punching test



—Punching conditions—  
 Processed material : 590 MPa class high tensile strength steel sheet  
 Sheet thickness : 10 mm (0.9 mm coining surface)  
 Punching speed : 35 spm  
 Lubrication : Oil and chlorine free type coolant  
 Punching shape :  $\phi$  10.45 mm  
 Cutting edge stress : 223 kgf/mm<sup>2</sup>  
 Clearance : 7%  
 Punch : Tapered head punch RW coating

[Fig 2] Progression of peeling/wearing in punch cutting edge

	0 shots	50,000 shots	70,000 shots	100,000 shots
RW coating				
HW coating			—	—
Competitor's Al-Cr coating				—

In the HW coating, peeling began to develop at 50,000 shots, and the test had to be suspended, but for the RW coating, only some minor wearing of the coating was observed even at 1,00,000 shots, and we observed that it was still very much in usable condition. The durability achieved was also 2 times more than that of the HW coating.

For the competitor's Al-Cr type coating, peeling was restricted to some areas at 50,000 shots, but at 70,000 shots, the peeling progressed rapidly and the wear and tear of the punch base material was observed. Therefore, the MISUMI RW coating surpasses other coatings in terms of the peeling resistance and the adhesive capability that it has to offer.

### Feedback from users

We would like to share the feedback that we have received from our customers who have already been using the product.

Using the RW coating punch, has contributed to enhanced punch life and durability, and helped in the reduction in mold maintenance efforts and product consumption rate.

No.	Processed material				Punch			Coating being used			RW coating		① vs ② Life
	Component name	Material	Tensile strength	Plate Thickness (mm)	Manufacturer	Cutting edge diameter P dimensions (mm)	Cutting edge stress (kgf/mm <sup>2</sup> )	Manufacturer	Coating Name	Life ① shots	Life ② shots		
1	Automobile chassis components	High tensile strength steel	590 MPa class	10	MISUMI	10.45	223	MISUMI	HW coating	50,000	100,000	2.0 times	
2	Automobile Door components	High tensile strength steel	590 MPa class	3.2		6.2	99		HW coating	100,000	300,000	3.0	
3	Automobile electrical components	High tensile strength steel	590 MPa class	2.3		5.5	80		HW coating	50,000	185,000	3.7	
4	Building and equipment components	Ferrous material	Approx. 440 MPa	12		13	148		HW coating	12,000	30,000	2.5	
5	Automobile interior components	High tensile strength steel	980 MPa class	1		7	46		TiCN coating	40,000	430,000	10.6	
6	Automobile chassis components	High tensile strength steel	590 MPa class	5		5	192	Organization A	Al-Cr based coating	55,000	100,000	1.8	
7	Automobile electrical components	Stainless steel	Approx. 440 MPa	6		6.5	148	Organization B	Al-Cr based coating	40,000	70,000	1.8	
8	Automobile interior components	High tensile strength steel	980 MPa class	1.8		4.6	125	Organization C	Ti based coating	80,000	100,000	1.3	
9	Automobile electrical components	High tensile strength steel	590 MPa class	2.3		5.5	80	Organization D	Ti based coating	100,000	185,000	1.9	

## ■ About DLC coating punches

Today, press treatments in which non-ferrous metal materials like aluminum alloy are used as the chief ingredient are becoming increasingly popular as it helps in creating a light-weight and much more malleable product. As opposed to steel, aluminum has a lower melting point and lesser hardness, and can be easily attached to the punch or the pilot punch cutting edge. However, it can lead to issues like poor accuracy of the pore or mis feed etc. This has created several challenges in the shop floor.

Adhesion is caused by the higher affinity of the punch (steel) with aluminum. This adhesion problem continues to exist even after lapping of the punch cutting edge or using a TiCN coating, and so this has promoted the use of DLC coating, which is smoother and has a lower friction coefficient.

Though the conventional DLC coating offered a high level of hardness, the adhesive capability of the punch base material was inadequate, and this was causing problems like adhesion due to premature peeling off of the coat.

The MISUMI DLC coating is an amorphous carbon film whose composition is more or less similar to that of a diamond, and offers high level of hardness and adhesive capability compared to the conventional DLC coating. It is effective in situations where there is wear and tear of the punch cutting edge resulting from the loss of adhesion with the adhesive product.

### Technical specification of the DLC coating

Types of film	Amorphous carbon film
Hardness (HV)	Above 3000
Film thickness (μm)	0.1 ~ 0.2
Friction coefficient (No lubrication for steel)	0.15
Heat resistance (°C)	500°C
Color	Interference color ※

※The color could differ based on the thickness of the DLC coat film, but this does not affect the functionality of the DLC coat treatment punch.

## ■ Features of the DLC coating punches

### 1 : Super hard

MISUMI DLC coating does not contain hydrogen, and has a coupling property that is more or less close to diamond, therefore offering a high level of hardness (More than 3000 HV) . The regular DLC coating usually contains hydrogen, and the hydrogen inhibits the carbon bonding leading to reduced hardness.

### 2 : Low friction coefficient

The MISUMI DLC coating film is smooth because of its amorphous composition, and offers the advantage of a low friction coefficient of 0.15 as opposed to a friction coefficient of 0.3 offered by the TiCN film. The affinity to the aluminum material is also low, therefore offering superior adhesion resistance.

Since the friction coefficient is low, there have also been cases where it has been used in press treatments not involving lubrication.

### 3 : High adhesion

A special surface treatment has been carried out to enhance the adhesive capability.

The DLC film is a fine film between 0.1 ~ 0.2 μm, and has an excellent crack-resistance property allowing it to easily withstand any sudden bulging in the punch base material due to external force.

## [Results of film adhesion capability test]

Plastic deformation was carried out using a Rockwell indenter, and the adhesion capability of the film was verified.

In case of the DLC coating of the competitors, there was peeling off of the coating around the Rockwell impression, but for the MISUMI DLC coating, there were no peeling or cracks, and we were able to confirm that this coating demonstrated superior adhesion with the punch base material.

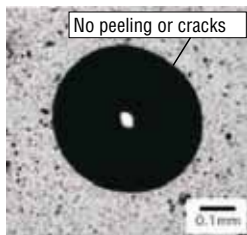

MISUMI DLC coating

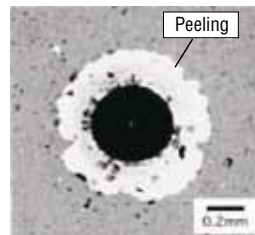

MISUMI DLC coating

Test method : Peeling evaluation using Rockwell Impression test (C scale)

Test load : 150 kgf

Base material : SKH51 equivalent (HRC61 ~ 64)

## ■ Points to be noted

DLC coating is meant for use in press treatments of non-ferrous metals like aluminum, brass, or copper and so on which have low melting point and low level of hardness.

In case this coating is used in a press treatment involving ferrous materials, the carbon component inside the DLC film will bond with the iron, leading to decarburization, peeling and wear and tear of the film. Therefore, it is not recommended for such kind of press treatments.











## ■ Punching test results

### 〈Test conditions〉

Processed material : Aluminum alloy A6061—T6  
 Sheet thickness : 1 mm Punch cutting edge :  $\phi$  5  
 Clearance : 5% SPM : 200  
 Lubrication : No lubrication  
 Punch material : SKH51 equivalent











### MISUMI DLC coating

〈SKH51 equivalent (Base WPC®) + MISUMI DLC〉

	1,000 shots	10,000 shots	30,000 shots	50,000 shots	70,000 shots	100,000 shots
Punch side	—					
Cut end surface characteristics	—					

### Competitor DLC coating

〈SKH51 equivalent (Base lapping) + Competitor DLC〉

	1,000 shots	10,000 shots	30,000 shots	50,000 shots	70,000 shots	100,000 shots
Punch side	—					
Cut end surface characteristics	—					

### TiCN coating

〈SKH51 equivalent + Our TiCN〉

	1,000 shots	10,000 shots	30,000 shots	50,000 shots	70,000 shots	100,000 shots
Punch side		—	—	—	—	—

In case of competitor's DLC coating, adhesion occurred in the punch cutting edge at 50,000 shots, and at 70,000 shots, the peeling was more enlarged. For the MISUMI DLC coating, there was very minimal adhesion even after 100,000 shots, and the coating did not peel off. For the TiCN coating, the adhesion started at 1,000 shots, and since there was a risk of the adhesion going above the allowed clearance level, we suspended the test immediately.

## ■ Feedback from Customers

We would like to share the feedback that we have received from our customers who have already been using the product.

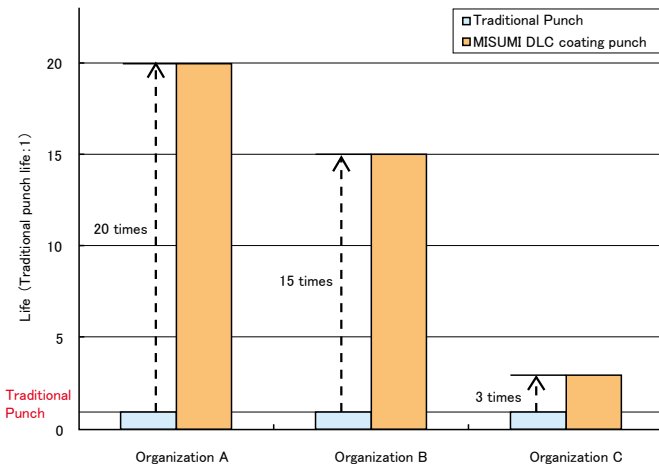

### Organization A 20 times (1 million shots)

Component : Daily commodities Sheet thickness : 0.2mm  
 Application : Shear Lubrication : Yes  
 Processed material : Aluminum A5052  
 Traditional punch : Powdered high speed steel (Not treated)  
 Durability of traditional punch : Exchange required at 50,000 shots (Cut end surface defect)

### Organization B 15 times (30,000 shots)

Component : Automobile components Sheet thickness : 1.6mm  
 Application : Shear Lubrication : No  
 Processed material : Aluminum A6061  
 Traditional punch : SKD11 (Not treated)  
 Durability of traditional punch : Exchange required at 2,000 shots (Pore defect)

### Organization C 3 times (300,000 shots)

Part : Electrical components Sheet thickness : 1mm  
 Application : Shear Lubrication : No  
 Processed material : Aluminum A5052  
 Traditional punch : SKH51 (Lapping)  
 Durability of traditional punch : Exchange required at 100,000 shots (Pore defect)

The use of the DLC coating multiplies the punch life by several times as compared to the traditional punch. Apart from suppressing the adhesion, it has been found to offer benefits like improved shape during product deformation, reduced need for lubrication and much more.

## ■ Punches for heavy load and tapered head punches

During punching of materials such as thick sheet and high-tensile steel sheet, in addition to wear, breakage, and chipping of the punch tip, the punch head frequently becomes damaged. The main causes of damage to the head of the punch are stress concentration and tensile impact force at the punch head. MISUMI punches for heavy load and tapered head punches are punches designed for greater strength by changing the profile shape of the punch head.

## ■ Causes of damage to the punch head

### 1. Stress concentration [Fig. 1]

Because of the rapid change in shape between the shank and head, stress becomes concentrated in the punch head. As a result, depending upon the tip diameter and the shank diameter, there are cases in which the head is subjected to greater stress than the tip, causing it to become damaged.

- A punch for heavy load has a larger radius of curvature below the head than a standard punch, relieving the concentration of stress. However increasing the radius of curvature below the head also increases the head outer diameter, which is disadvantageous in terms of cost and installation space. Therefore excessive increases in the radius are impractical.
- A tapered head punch has the same radius of curvature below the head as a punch for heavy load, however it also uses a tapered shape for the head that further reduces stress concentration.

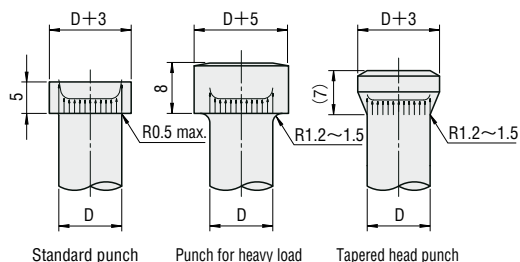

[Fig. 1] Conditions of stress concentration

### 2. Tensile force due to elastic waves [Fig. 2]

A punch is subjected to a large compressive force during the punching operation, and at the moment when the punch pierces the material (break-through), this compressive force is suddenly released, generating an opposite large tensile impact force.<sup>1)2)</sup>

This tensile impact force is a large force which in some cases may equal the punching load, and which can cause damage to the punch head.

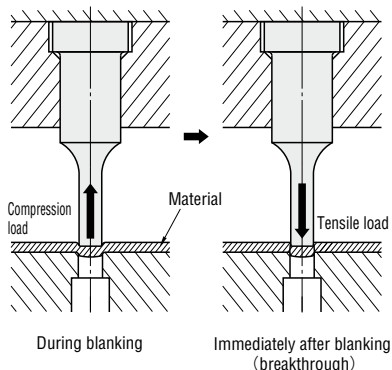

[Fig. 2] Conditions of tensile force generation

[Reference texts]

- 1) Nagai, Shimanuki, Spring Lecture on Plastic Forming 1985
- 2) Takaishi, Maeda, Mori, et al Spring Lecture of Plastic Forming 1981

## ■ Characteristics of punches for heavy load and tapered head punches [Fig. 3~Fig. 5]

### 1. Thickness of the punch head

A thicker punch head is set in order to prevent shear failure due to tension resulting from impact force.

- Punch for heavy load: 8 mm
- Tapered head punch: Approx. 7 mm (Thickness of flange combined with ring: 8 mm)

### 2. Outer diameter of punch head and radius of curvature below the head

In order to relieve stress concentration and for reasons of cost performance, a punch for heavy load has a radius of curvature below the head of 1.2 ~ 1.5 R, and a head outer diameter of D+5 mm (D: punch shank diameter).

A tapered head punch has a radius of curvature below the head of 1.2 ~ 1.5 R, and a head outer diameter of D+3 mm. It is designed so that when used in combination with tapering, it has the same outer diameter (D+5) as a punch for heavy load.

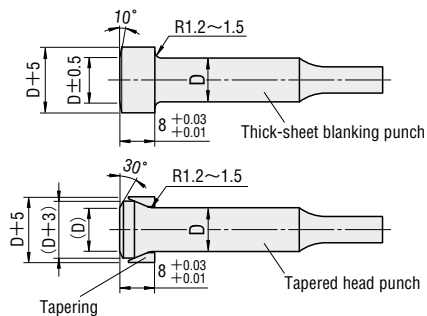

[Fig. 3] Punch shape

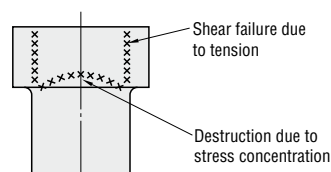

[Fig. 4] Punch head destruction

### 3. Periphery of punch head top surface

The periphery of the top face of the punch is inclined. This is in order to prevent breakage of the punch head due to the application of a bending moment near the periphery in the event that the axial center of the punch is out of alignment.

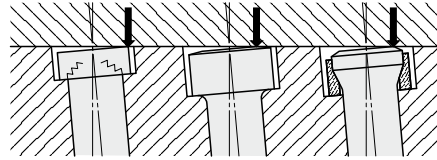

[Fig 5] Reduction of bending moment

### Strength of the punch head..... [Refer to Fig. 6 and Fig. 7]

With the tensile strength of a standard punch considered as 1, the tensile strength of a punch for heavy load is approximately 1.5, and that of a tapered head punch is approximately 1.9. [Fig. 6]

Comparing the fatigue strengths of the punch heads, when a comparison is made at  $10^4$  strokes, then a punch for heavy load is able to withstand approximately 1.8 times the stress that a standard punch can. When a comparison is made at stress of 784 MPa [80 kgf/mm<sup>2</sup>], a punch for heavy load head is able to withstand nearly 60 times the number of punch strokes that a standard punch can. [Fig. 7]

Because the tensile strength of a tapered head punch is approximately 20% higher than that of a punch for heavy load, a tapered punch head is estimated to have fatigue strength that is equal to or better than a punch for heavy load. For this reason, a tapered head punch is suitable for applications which may cause head damage even with a punch for heavy load, such as punching of high-tensile steels of 980 MPa [100 kgf/mm<sup>2</sup>] or higher, spring steels, or hardened steels.

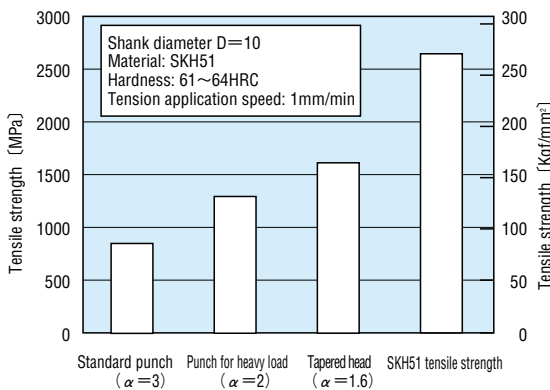

[Fig. 6] Punch head tensile strengths for different punches (D=10, SKH51)  
α: Stress concentration coefficient of punch head

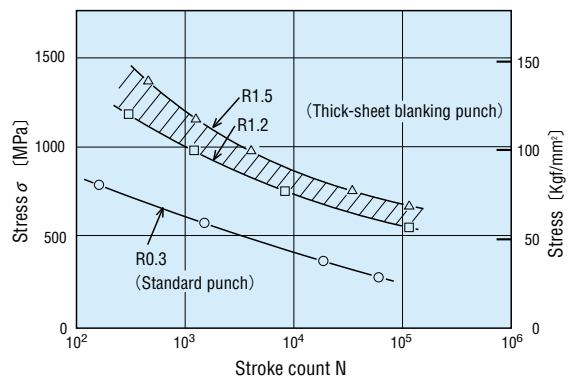

[Fig. 7] Fatigue strength of thick-sheet punch and standard punch (D=5, SKH51)

### Notes for use

- The selection standards for punch tip diameter and shank diameter are shown beginning from Products Data P.1593~. The optimal punch (tip diameter and shank diameter) can be selected from the relationship between the shearing resistance of the workpiece, the sheet thickness, the punch diameter, and the total number of punching operations.
- With a tapered head punch, a punch and taper ring are fit together in order to perform machining. Therefore be sure to use a combination of items which bear the same identification mark.

**[PRODUCTS DATA] CONDITIONS UNDER WHICH FRACTURE, BREAKAGE, AND ABNORMAL WEAR ARE LIKELY TO OCCUR**

**■ Conditions under which fracture, breakage and abnormal wear are likely to occur**

Factor		Condition	Possibility of damage to tip			Possibility of large wear			Possibility of thin punch breakage		
			Large	Medium	Small	Large	Medium	Small	Large	Medium	Small
Tool material		Heat-treatment hardness too high	○				○		○		
		Material not uniform (ex.: internal defect)	○			○			○		
		Materially similar tool and workpiece materials	○			○			○		
Workpiece material		Presence of oxide film on surface			○	○					○
		High hardness		○		○			○		
		Large elongation and high viscosity	○			○			○		
Working conditions	Tool contour	Too long relative to diameter			○		○		○		
		Small punch shoulder roundness			○		○		○		
		Sharp corners on punch tip	○			○					○
		Rough surface finish	○					○			○
	Clearance	Extremely small	○			○			○		
		Uneven	○			○			○		
	Lubrication	Not lubricated	○			○			○		
		Incorrect lubricant		○			○			○	
	Bridge width	Uneven	○			○			○		
	Punch guide	No punch guide		○		○			○		
		Poor accuracy of punch guide		○			○		○		
	Holding of workpiece	No plateretainer (when fixed stripper is used)		○			○			○	
		Insufficient plate holding force		○			○				○
	Abnormal punching	Double shot or two-sheet shot	○			○			○		
Press, die set		Low press rigidity		○		○				○	
		Poor press accuracy		○		○				○	
		Poor die set accuracy		○		○				○	

(Press Working Data Book, 1980, The Nikkan Kogyo Shimibun Ltd.)

# [PRODUCTS DATA] CARBIDE TOOL MATERIALS FOR WEAR RESISTANCE

## ■ Comparison table of carbide tools for wear resistance

Application	Application category code	Tungaloy	Sumitomo Electric Hardmetal	Mitsubishi Materials	Dijet	Hitachi Tool Engineering	Fuji Die	Nippon Tungsten	Sanalloy	EVERLOY	Silver Alloy	
For general wear-resistant, impact-resistant tools	V10	D10	D1	GT105	D1	WH10 WH20	D10 D20	G1	DA10 DA20 DA25	H1 G1 KD05	G1 G2	
	V20	D20 D25	D2	GT110 GT115	D2	WH30	D40 D50 C50 G55	G2	DA30 VA30	G2 KD10 A10W	G3	
	V30	D30	D3 ED30	GT120	D3 NC2 NC6 NC8	WH40	D60	G3 G20	DA50 VA40	G3 G4 KD20 MC30	G4	
	V40 *	D40	G5 ED50	GT130	G5 NC10 GD195	WH50	C60 G65	G30 G40	DA60 VA50 EA50	G5 TB6 KD40	G5 6F	
	V50 *	D50	G6	GT135 GT130S GT140	MH4 GD174 GD201	WH60	C70 C84 G70 G85	G50 G60	VA60 VA70 EA60 EA70	TB7	G6 F65 G65	
	V60 *	D60 D70	G7 G8	GT140S GT150S	MH5 MH7 GD206	WB60	C95	G80 SD1	VA80 EA80 EA90	G8	G7 G8 7F 8F	
Ultrafine grain carbide	For cutting tools	Z01	F MD08F	F0	ZH104 SF10 MF10	FZ05 FB10	NM08	F08				
		Z10	M MD10 MD05F	XF1 F1 AFU	HT110 MF20	FZ10 FZ15 FB15	NM15	F10 M10	FN10 FN20		EF05	
		Z20	MD15 MD20 EM10	AF0 SF2 AF1	TF15 UF30	FZ20 FB20	BRM20 EF20N	F20	FN30 SF30	FD25	EF10	
		Z30	UM	A1 CC		FZ25	NM25		FN40 SF50		EF20	
	For wear and impact resistance	V10	F	F0 SF1 ED10 AFU	UF20	FB15 FZ10 FZ15		F08 F10 F20 M10	FN10 FN20		EF05 EF10	
		V20	EM10	AF0 AF1	UF30	FB20 FZ20			FN30 SF30	FD25	EF20	SF20 SF05
		V30		A1 CC		FZ25	NM25		FN40	FD15		SF25 SF30
		V40 *					NM40		SF50			

\*: Standard of the Japan Cemented Carbide Tool Manufacturers' Association

## ■ Carbide application category

Unit: Wt%

Application category code	Hardness HRA	Transverse rupture force N/mm <sup>2</sup> (kgf/mm <sup>2</sup> )	Metal component		Hard phase component	
			Co	W-based hard phase		
V10	89 or more	1170 or more {120 or more}	3~6		88~91	
V20	88 or more	1275 or more {130 or more}	5~9		88~90	
V30	87 or more	1471 or more {150 or more}	8~16		78~87	
V40	85 or more	1864 or more {190 or more}	11~20		73~85	
V50	83 or more	2060 or more {210 or more}	14~25		70~82	
V60	78 or more	2256 or more {230 or more}	17~30		65~78	

(Standard of the Japan Cemented Carbide Tool Manufacturers' Association CIS 019C—1990)

Notes 1. The application category codes from V10 to V30 and the corresponding values are in accordance with JIS B 4053.

2. The application category codes must not be used as material type codes.

3. Some carbide manufacturers have multiple material type codes that correspond to the same application category code.

## ■ Standards for carbide selection

Major category	Product name		Application category code					
	Part name and type		High ← Wear resistance → Low Low ← Impact resistance → High					
			V10	V20	V30	V40	V50	V60
Trimming die	Die	When load is small						
		When load is large						
Drawing die	Drawing die	When load is small						
		When load is large						
Drawing die	Drawing punch	When load is small						
		When load is large						
Powdered metal forming die	Die body	Round						
		Irregular						
		Punch						
Other wear-resistant, impact-resistant tools and components	When impact is small	Gauge, valve, nozzle, seal ring, precision ball, etc.						
		Bending die, crusher, spike, etc.						
		Engraving punch, coining die, coining punch, impact die, swaging die, nail-making tool, hot extrusion die, polishing discs, etc.						

(Standard of the Japan Cemented Carbide Tool Manufacturers' Association CIS 019C—1990)

## ■ Ultrafine grain carbide

Application category code	Hardness HRA	Transverse rupture force N/mm <sup>2</sup> (kgf/mm <sup>2</sup> )
Z01	92 or more	1177 or more {120 or more}
Z10	91 or more	1275 or more {130 or more}
Z20	89.5 or more	1471 or more {150 or more}
Z30	88.5 or more	1668 or more {170 or more}

(JIS B 4053—1989)

# [PRODUCTS DATA] SELECTION OF BUTTON DIES

The following is a summary of the procedure for the correct clearances of punches and dies and the outside diameters of button dies for ordinary punching work.

- STEP 1** Select the material code from Table 1.  
(Example: SPCC1.6t.....Material code 42)
- STEP 2** Select the hole tolerance code from Table 2.  
Example:  $\phi 6 \pm 0.15$ .....Hole tolerance code S
- STEP 3** Determine the clearance from Table 3 based on the material type.  
Example:  $10\% \times 1.6 = 0.16$
- STEP 4** Determine the die hole diameter using the following formula.  
Punch end diameter + (2 × Clearance) = Die hole diameter  
Example:  $6.0 + (2 \times 0.16) = 6.32$
- STEP 5** Determine the outer diameter of the die from Table 4, according to the material code, hole tolerance code, and the die hole diameter.  
Example: Material code 42, hole tolerance code S  
Die hole diameter  $\phi 6.32$ .....Outer diameter  $\phi 13$
- STEP 6** Determine button die length L in the design, and then select a headed type or a straight type.  
Example: Length 16, headed type
- STEP 7** Place the order using the catalog number.  
Example: MHD 13—16—P6.32.....Qty. 10

(Table 1) Material codes

Tensile strength kgf/mm <sup>2</sup>	Material thickness		
	1 or less	1~2	2~4
20 or less	21	22	24
40 or less	41	42	44
80 or less	81	82	84

(Table 2) Hole tolerance codes

	Precision grade	Standard grade
Code	P	S
Hole tolerance	$\pm 0.1$ or less	More than $\pm 0.1$
Hole cross section	Shear surface 50%	Shear surface 30% or less
Application	Shaft bearing Rivet hole	Drill hole Ventilation hole Unfinished tap hole Weight-reduction hole

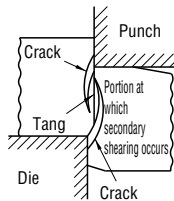

(a) Clearance too small

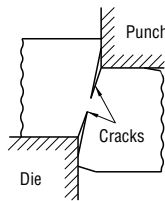

(b) Appropriate clearance

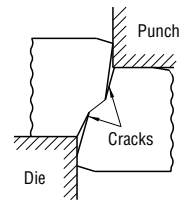

(c) Clearance too large

### Differences in crack growth according to the amount of clearance

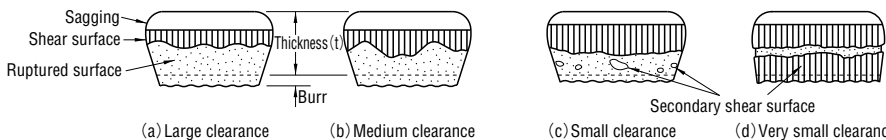

### Effects of clearance on the cut cross-section shape of sheared products

(Table 3) Standard for clearance selection

Material type		Tensile strength kgf/mm <sup>2</sup>	Recommended clearance (one side) %	
			Precision grade P	Standard grade S
Aluminum Aluminum alloys	Soft	Less than 10	3	6
	Medium	10~18	4	8
	Hard	20 or more	8	10
Tough pitch copper	Soft	20 or less	6	8
	Hard	28 /	8	10
Brass	Soft	28 /	4	8
	Hard	35 /	8	10
Phosphate bronze	Soft	30 /	6	10
	Hard	50 /	10	15
Steel	Extra soft	28 /	6	10
	Soft	34 /	10	12
	Hard	70 /	12	15
Stainless steel	Soft	60 /	6	12
	Hard	100 /	8	15
Silicon steel		35~39	8	12
Vinyl chloride fiber		4~8	3	5
Phenol laminate		5~10	4	4

(Table 4) Recommended outside diameter for button die

Material code Hole diameter \ Hole tolerance	21		22		24		41		42		44		81		82		84	
	P	S	P	S	P	S	P	S	P	S	P	S	P	S	P	S	P	S
1.0 ~ 1.99	6	6	6	6	—	—	6	6	6	6	—	—	8	8	8	8	—	—
2.0 ~ 2.99			8	8	8	8	8	8	8	8	8	10	10	10	10	10	10	10
3.0 ~ 3.99	8	8	10	10	10	10	10	10	10	10	13	13	10	10	13	13	13	13
4.0 ~ 4.99					10	10			13	13			13	13				
5.0 ~ 5.99	10	10	10	10	13	13	13	13	13	13	16	16	13	13	16	16	20	20
6.0 ~ 6.99																		
7.0 ~ 7.99	16	16	16	16	16	16	16	16	16	16	16	16	16	16	16	16	20	20
8.0 ~ 8.99																		
9.0 ~ 9.99	16	16	16	16	16	16	16	16	16	16	16	16	16	16	16	16	20	20
10.0 ~ 10.99																		
11.0 ~ 11.99	20	20	20	20	20	20	20	20	20	20	20	20	20	20	20	20	25	25
12.0 ~ 14.99																		
15.0 ~ 19.99	25	25	25	25	25	25	25	25	25	25	25	25	25	25	25	25	25	25
20.0 ~ 25.00																		
	38	38	38	38	38	38	38	38	38	38	38	38	38	38	38	38	38	38

# [PRODUCTS DATA] SCRAP RETENTION REVERSE TAPER DIES

## —GUIDE—

### What is a scrap retention reverse taper dies?

In recent years, more and more high-tension materials with high pulling capacity are undergoing the punching process as a part of weight reduction activities. Generally, in high tensile materials the compression amount of the scrap is large [Fig.1] whereas the length of the cross section shortens [Fig.2]. Thus there has been a rise in cases where the existing countermeasures are failing to control the scrap lifting. MISUMI has developed a reverse taper die where the taper is provided inside the die considering the compression amount of the scrap. By providing a very small taper, even the compressed slug produces friction with the die which proves effective against scrap lifting.

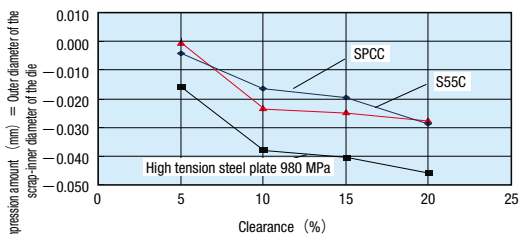

Effect of the materials to be processed on the outer diameter of the scrap [Fig.1]  
(normal die,  $\phi 10$ ,  $T=1\text{mm}$ )

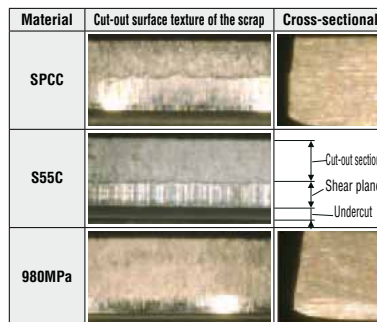

[Fig.2] Cut-out surface texture of the scrap

### Scrap retention reverse taper dies- Principle and Features

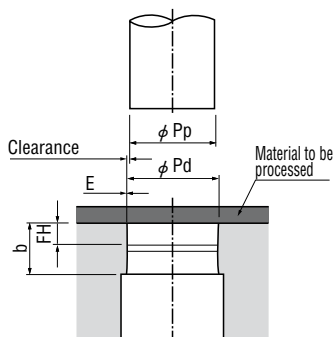

[Fig.3]  
Before punching

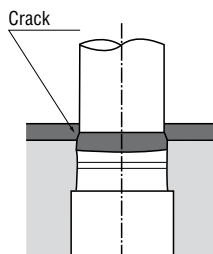

[Fig.4]  
Cracks in the material to be processed  
(usual clearance)

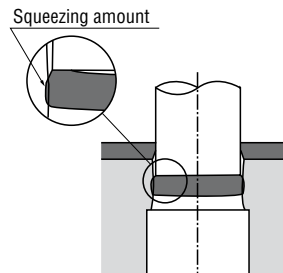

[Fig.5]  
As the punch goes on penetrating the inner diameter of the reverse taper die goes on decreasing. Therefore, the frictional force between the scrap and die increases because of the squeezing effect on the scrap. As a result, the scrap lifting is prevented.

#### 1) Principle of the scrap retention reverse taper dies [Fig.3] [Fig.5]

By providing a very small taper at the edge of the die, the inner side of the edge is made smaller than the scrap. As a result, the compressed scrap gets squeezed and the friction with the die increases, thus preventing the scrap lifting.

The compression amount of scrap may vary depending upon the punching conditions. However, at MISUMI, we have standardized the taper width as per the make specified by our customers as well as considering the clearance, thickness of the sheet and the tensile strength of the materials to be processed.

#### 2) Cost reduction for all parts

The die unit is costlier as compared to other dies, however, just using the scrap retention reverse taper dies. If Jector punch and scrap retention taper die (SR-□□) (below SR die) are used together and the prices are compared, the price of the die unit comes out cheaper and this makes it possible to reduce the total cost of the parts. Particularly, there are cases where the die cannot bear the load of high tension steel sheets (high tensile material) during punching, and breaks from the jector holes in the initial stages. The cost of repairing the die can be cut down effectively by using our product which uses a single die to prevent the scrap from lifting.

In addition, the reverse taper die is also effective in managing the sorting and scrapping costs related to screening the products which get dented as a result of the scrap lifting as well as in reducing costs related to repairing the dies.

### Caution items

- The optimum tapering width is adopted to prevent scrap lifting, however as many conditions can cause scrap lifting there may be variations in the results.
- Set the pushing volume of the punch larger than the FH dimensions [Fig.6] to make sure that the scrap is pushed on the inner side of the tapered part.
- Specify the correct clearance so that diameter of the inner side of the tapered part is set larger than the punch diameter.
- The blade edge will deform if it is polished again as that part is tapered. The amount of deformation will vary depending upon the taper width (max. 0.05mm for one side), tapering depth and the amount of re-polishing.
- Material to be processed (MT), Clearance (C) and Tensile strength (TS) are used as taper processing data for reverse tapering. Specify the blade edge dimensions (P/W/R) through button die finishing dimensions.

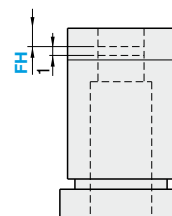

[Fig.6]

## Comparing the frictional forces

The force when the scrap is pushed in to the die (frictional force between scrap and die) was measured for scrap retention reverse taper dies and compared with those of normal dies (with no countermeasures for scrap lifting) and SR dies.

The frictional force for the reverse die is much greater as compared to that of normal dies and SR dies. The scrap clings to the die and proves effective against scrap lifting even when punching highly tensile materials and for scrap with high compression amounts.

The SR die locally squeezes at the cut-out section from the inclined groove, whereas scrap retention reverse taper dies squeezes through whole circumference thus increasing the length of the cross sectional surface as compared to a normal die [Fig.8] .

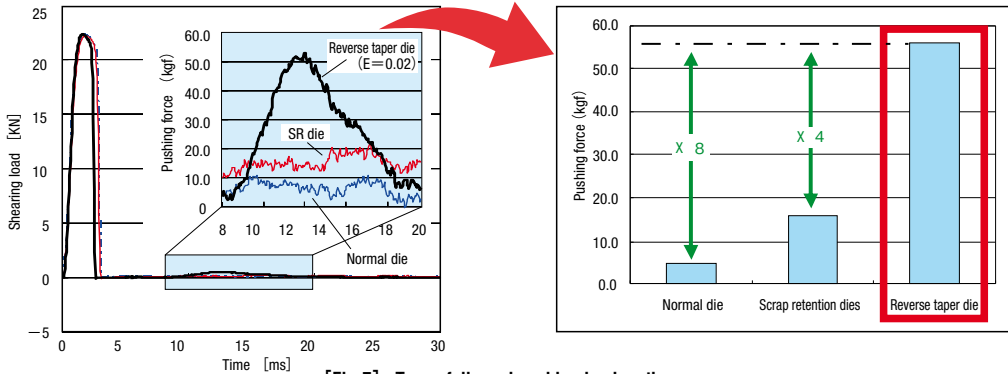

[Fig.7] Type of die and pushing load on the scrap

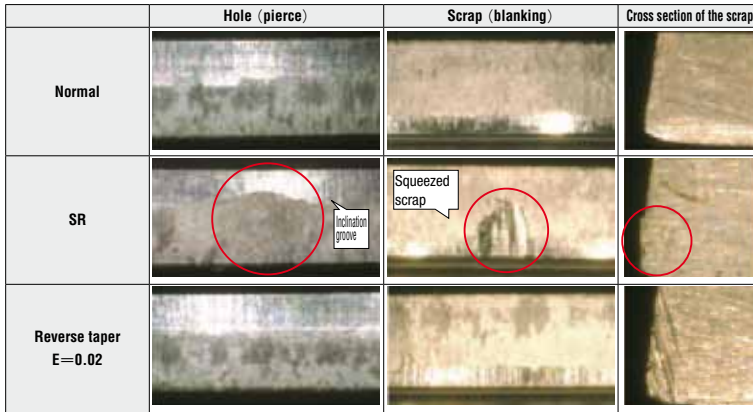

[Fig.8] Cut out section textures for different die shapes

## Punching test results

To check the endurance of the scrap retention reverse taper dies, the punching test conducted for 100 thousand times using a 980 Mpa high tensile steel sheet (high tensile material) .

[Fig.9] Comparison of frictional forces for reverse taper dies

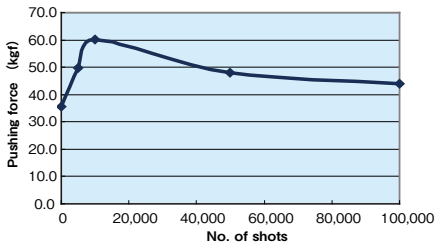

[Punching conditions]  
 Material to be processed :  
 980 high tensile material  
 Thickness of the sheet : 1.0mm  
 Punch diameter :  $\phi$  10mm

[Fig.10] Change in burr height following the increasing punching count

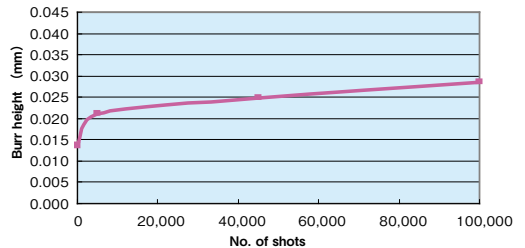

### <Result>

Test result: Scrap lifting and scrap accumulation did not occur. Though the frictional force between scrap and die [Fig.9] varies according to the number of shots; the force from the initial punching shots is maintained. When the abrasion was checked after 100 thousand shots, a 0.001 mm abrasion was observed on the tapered part. However as the frictional force from initial shots could be maintained throughout, the results seem to remain constant even after several shots. The burr height [Fig.10] increases gradually along with the number of shots. The burr height was at 0.03 mm even after 100 thousand shots.

# [PRODUCTS DATA] SCRAP RETENTION DIES

## —GUIDE—

Scrap lifting during press operations is caused by factors such as product defects or damage to the dies, and can become a serious problem. It is said that scrap lifting is particularly likely when punching small holes in thin sheetor during side cuts when there is little restraining force with the die.

### Causes of scrap lifting

The causes of scrap lifting are thought to include adhesion due to vacuum, adhesion to the punch tip, adhesion due to oil, magnetic force of the punch, and lifting-up by the die compressed air.

Also, with ordinary clearances, because the sizes of punching scrap are smaller than the diameter of the die holes, scrap lifting occurs easily.

### General countermeasures to scrap lifting

The primary means of preventing scrap lifting is to ensure that

$\text{Force of adhesion onto the punch} < (\text{Die friction force} + \text{Punch scrap weight})$ . For this purpose, a variety of steps have been taken, including the following.

- 1) **Punch countermeasures** .... Machining of the tip end (shear angle, projections), air blows, use of a jector punch, etc.
- 2) **Die countermeasures** ..... Sucking scrap out with a vacuum, increasing the surface roughness of the blade inner surface, fine chamfering of the blade, etc.
- 3) **Other countermeasures** .... Profile shape changes, reducing clearances, increasing the punch and die penetration depth, etc.

Generally, the use of suction generated by a vacuum is the method most often used. However this method requires that structural considerations be incorporated beginning from the time of die design, and involves troublesome adjustments for factors such as variation in installation work or suction force. The use of a jector punch requires processing of the jector pin when regrinding of the punch occurs, and changing the surface roughness of the blade inside surface also involves troublesome reprocessing after regrinding is completed. MISUMI scrap retention dies resolve these problems through the use of special machined grooves.

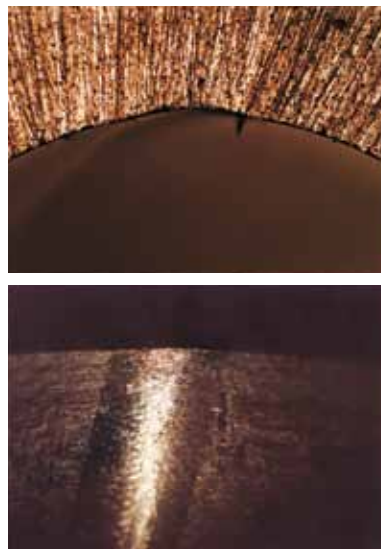

[Fig. 1] Groove shape of dies with countermeasures for scrap retention

### Principles and characteristics of scrap retention dies

#### 1) Principle of dies with scrap retention

Two or more slanted grooves are machined in the inside surface of the die in opposite directions as viewed from the center. The scrap initially punched out during the punching process forms small projections along the slanted grooves in the die. When these are pushed still farther down to the bottom by the downward stroke of the punch, these projections become compressed by the sides of the die (“ironing” effect), increasing the friction force and preventing scrap lifting from occurring. Because the slanted grooves are machined in opposite directions rather than in a spiral pattern, there is no risk of scrap lifting caused by rotation during the punch upward stroke.

#### 2) Hole shapes and die types

The use of scrap retention dies is possible and effective not only with round and shaped die holes (where scrap lifting is more likely to occur), but also with notched shapes (side cuts) where there is little binding force with the die.

#### 3) Easy handling and lower total costs

Because the scrap retention effects can be achieved simply by incorporating scrap retention countermeasures into an existing die, these dies can be used with existing dies, eliminating any need for troublesome steps at regrinding or reprocessing after regrinding. Although the cost is somewhat higher than conventional dies, the cost difference is approximately the same as the difference between an ordinary punch and a jector punch. When the benefits of these dies and maintenance costs are considered, the added value of these dies is extremely high.

## Effects of the cut cross-section shape

Scrap retention dies are effective because of the slanted grooves (approx. 0.005 mm~0.1 mm) that are machined on the inner surface of the dies. As a result, clearance increases at the specific parts of the workpiece which correspond to locations where these special grooves are machined. This causes slight changes in the cut cross section, as shown in Figure 2. What this means is that relative to the parts where the grooves were not machined, the shear droop (R), fracture surface length (H), fracture surface dimensional difference (C), and burr height (B) are larger, and the shear surface (S) is smaller. As a result, please use caution in cases when many shear surfaces are required, such as during shaping work, and when fracture surface dimensional difference are a problem.

Shear droop	R1 < R2
Shear surface length	S1 > S2
Fracture surface length	H1 < H2
Fracture surface dimensional difference	C1 < C2
Burr height	B1 < B2

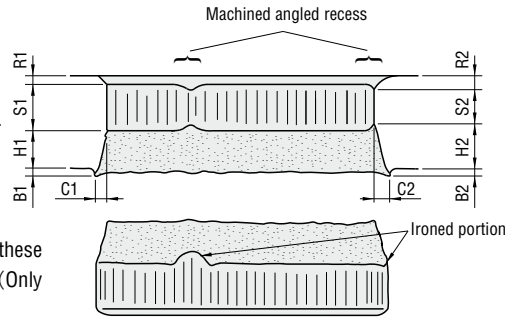

[Fig. 2] Shear plane shape due to die with countermeasures for scrap retention

## Applicable range

### 1. Hole diameter: $\phi 0.8 \text{ mm} \sim \phi 48 \text{ mm}$

Smaller holes are believed to involve greater risk of scrap retention, however these dies can be used beginning from a minimum hole diameter of  $\phi 0.8 \text{ mm}$ . (Only the precision grade can be used with diameters smaller than  $\phi 1.0 \text{ mm}$ .)

### 2. Workpiece material: Can be used up to tensile strength of $1177 \text{ N/mm}^2 (120 \text{ kgf/mm}^2)$ .

Scrap lifting is believed more likely to occur with materials that are harder and less ductile. The scrap retention dies can be used with tensile strengths up to  $1177 \text{ N/mm}^2 (120 \text{ kgf/mm}^2)$ , which covers nearly all of the broad range of workpiece materials.

⚠ With workpiece materials that have a tensile strength exceeding  $1177 \text{ N/mm}^2 (120 \text{ kgf/mm}^2)$ , the intended effects of the dies may not be achieved.

### 3. Workpiece material thickness: Can be used with materials of minimum thickness 0.1 mm

Due to factors such as oil— and vacuum—adhesion, scrap lifting is more likely to occur with thinner sheet thicknesses, resulting in trouble. Scrap retention dies can be used with sheets with thickness 0.1 mm or larger. (For materials with thickness of less than 0.15 mm, only precision grade dies can be used.)

### 4. Die material: Die materials can be selected from SKD11 (and equivalents), SKH51, powdered high-speed steel (HAP40), carbide V40 and super-fine carbide.

## Precautions

1. The special grooves are machined so as to deliver the best results and minimize the effects on the products, however there may be variation in the scrap retention effects due to a variety of conditions.

2. Punch and die penetration: Approximately 1 mm

In order to achieve the full benefits of the scrap retention die functions (increasing the force of friction with the die by the “ironing” effects), approximately 1 mm of penetration is required. Therefore, please consider this requirement during die design and at the time of regrinding.

3. Amount of regrinding: Approximately 1 mm (or to BC—1 mm when BC is used)

In order to achieve the full effects of the scrap retention die, regrinding to approximately 1 mm should be performed before use. (In order to achieve the scrap retention effects, the straight portion of the blade edge must be a minimum of 1 mm.)

## Ordering

In order to machine the slanted grooves which will provide the greatest scrap retention effect, and to minimize the effect on the product, in addition to the ordinary die dimensions, we also require the values for workpiece material thickness and clearance (one side).

• Workpiece material thickness: **MT**: minimum 0.15mm (Indicate in units of 0.01mm.) • Clearance **C**: minimum 0.01mm (Indicate in units of 0.005 mm.)  
Precision grade material thickness **MT**: minimum 0.10mm (Indicate in units of 0.01 mm.) Precision grade clearance **C**: minimum 0.005mm (Indicate in units of 0.001mm.)



Order

Catalog No. — **L** — **P** — **W** — **R** (R only) — **MT** — **C**  
SR—MHD13 — 30 — P7.00 — MT1.50 — C0.105

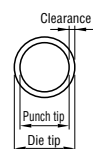

# [PRODUCTS DATA] NON-CLOGGING BUTTON DIES & SCRAP VACUUM UNITS

## —GUIDE—

### Causes of scrap clogging

In generally, the causes of scrap clogging are considered to be the points listed below.

- Straight part of the die tip is too long.
- Rear relief shape is unsuitable (reverse taper shape).
- Inside surface of the die is rough.
- Mis-centering of the holes in the die, backing plate, and die holder has caused steps to form.
- Punching scrap piles up and forms a bar shape, then falls in and clogs the relief hole.
- Scrap has become magnetized.

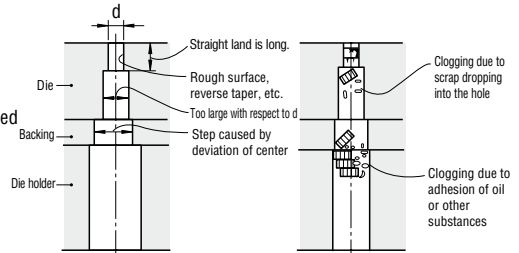

[Fig. 1] Causes of scrap clogging

1) "Presswork Troubleshooting" by Hiromi Yoshida, Fumio Ymaguchi

With thin sheet materials and small punching holes in particular, because the scrap is lightweight, scrap clogging can occur easily when even a slight obstruction exists.

### Non-clogging button dies (SV series)

#### 1) Principle and characteristics of non-clogging button dies

One concept for the prevention of scrap clogging is the following.

$$\text{Scrap discharge resistance (cause of scrap clogging)} < (\text{Scrap discharge force} + \text{Weight of scrap})$$

Because MISUMI non-clogging button dies have an air inlet hole near the tip, when they are used in combination with vacuum equipment, a downward flow of air is generated inside the die. This airflow boosts the scrap discharge force, thus reducing the incidence of scrap clogging.

For the vacuum equipment, please use a vacuum pump, vacuum cleaner (pail cleaner), or scrap vacuum unit. [Fig. 2]

#### 2) Applicability

	M	Shape of relief hole		Shank diameter		Tip diameter		Page
		Regular	Angular	D	P	P	P	
Steel	Equivalent to SKD11	○	—	6~10	1.00 ~6.00	P. 361		
	Equivalent to SKH51	○	—	3~ 5	0.50 ~2.50			
	Powdered high-speed steel	○	—	6~10	1.00 ~6.00			
Carbide	V40	○	○	3~10	0.50 ~6.00	P. 585, P. 591		
Precision grade carbide	V40	—	○	3~10	0.500~6.000	P. 516		
	Super fine grain	—	○	3~10	0.500~6.000			

#### 3) Use as a scrap retention countermeasure

It is possible to prevent scrap lifting by applying an additional BC alteration to shorten the tip length (length of the straight part), and by increasing the punch penetration in order to use the airflow to separate the scrap from one sheet at a time.

[Fig. 3]

Previous button dies used as scrap retention required shaving at a following process, or else were unusable when workpiece material thickness was less than 0.1 mm and clearance was small. However the MISUMI non-clogging button dies can be used as scrap retention in cases such as these.

(The additional BC alteration can only be applied to the angular type hole shape.)

#### 4) Precautions

- The non-clogging button dies are intended to be used in combination with a vacuum pump or other vacuum equipment. A button die used on its own will not prevent scrap clogging.
- If the air inlet hole at the top of the button die becomes clogged with lubricating oil, cutting chips, dirt, or other substances, the die will not function to full effectiveness. Therefore perform maintenance of the die regularly. After the die was stored for a long period, remove any solidified lubricating oil, dirt, or other substances clogging the air inlet hole before using the die.
- If the die is insufficiently airtight, it may not be possible to achieve the full suction effects.
- This product is designed primarily for punching of thin sheet material. If used with thick sheets, the full performance may not be achieved.

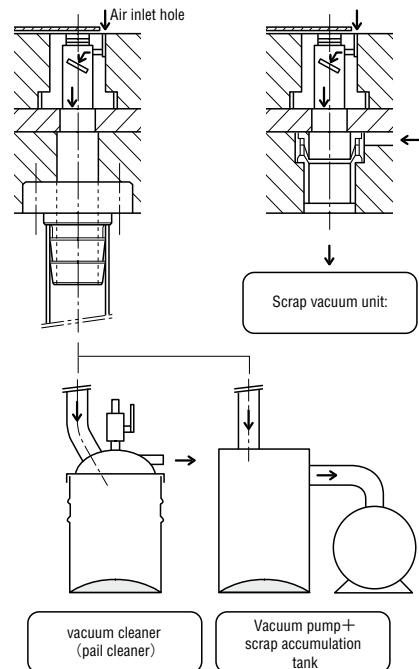

[Fig. 2] Examples of combinations with different vacuum devices

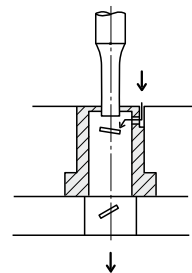

[Fig. 3] When used for scrap retention

## Scrap vacuum unit (SVBN)

### 1) Principle and characteristics of the scrap vacuum unit

- The scrap vacuum unit uses an air blow (compressed air) to create negative pressure inside the die, pushing the punching scrap (product) downward, and preventing scrap clogging and scrap lifting.
- Greater effectiveness can be achieved by using a non-clogging button die that includes an air inlet hole.
- Two air supply paths to the die holder can be selected: a machined groove, or a machined hole.
- Because the unit is recessed within the die holder, it can be installed as a scrap retention and non-clogging after die completion without requiring any major design changes.
- It is not necessary to machine an inclined hole to the die plate, die holder, or other parts.

### 2) Applicability

- Hole diameter  $d$  :  $\phi$  3 mm~16 mm
- Outer diameter  $D$  :  $\phi$  6 mm~20 mm

### 3) Precautions

- The magnitude of the suction force generated by the scrap vacuum unit varies depending upon the supplied air pressure, hose diameter, cross-sectional area and length of the plate air supply path, and the size of the unit.
- If the die is insufficiently airtight, it may not be possible to achieve the full suction effects.
- When multiple scrap vacuum units are used together, take steps to ensure that the airflow paths are equal. Note that in this case the airflow velocity will fall, causing the vacuum to decrease as well. The vacuum is proportional to the pressure of the compressed air and to the cross-sectional area of the flow path, and inversely proportional to the diameter of the vacuum unit and to the length of the flow path.
- Use a hose with a minimum outer diameter of  $\phi$  6 and a minimum inner diameter of  $\phi$  4.
- Although this unit can be used to prevent scrap lifting and clogging, it may not be able to resolve these problems under all conditions.
- Dimensions not listed in this catalog may be changed for the purpose of performance improvements.

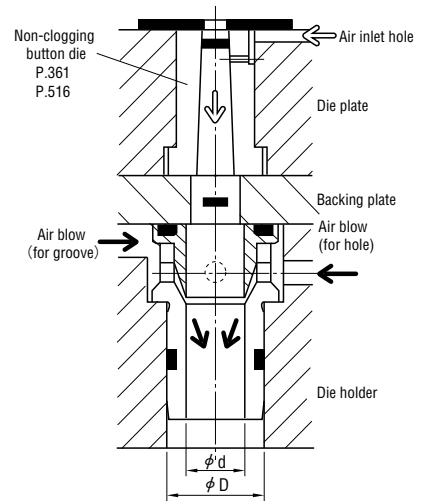

[Fig. 4] Example of use of a scrap vacuum unit

## Test data (reference values)

- Scrap suction performance (the degree of vacuum at the die tip) is maximized when suction is applied using a vacuum pump.
- The suction performance of the scrap vacuum unit or a vacuum cleaner (pail cleaner) is inferior to that of a vacuum pump, however because it is possible to drive the scrap vacuum unit using an existing compressor or other device, there is almost no need to purchase new equipment.
- Suction performance varies depending upon the size of the button die, the hose diameter and length, and other factors. The values presented here are intended only as an approximate guide.

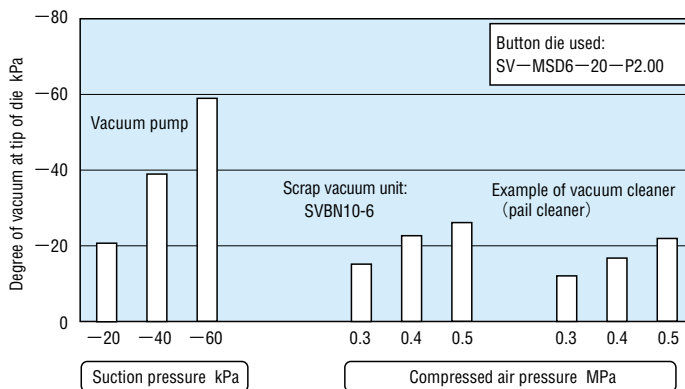

[Fig. 5] Comparison of different suction units

Note: The suction performance of the vacuum cleaner varies greatly depending on the model.

## ■ Effects of plate machining error and adhesive gaps on stripper guides

When the punch is inserted during die production, centering deviation may occur due to the effects of factors such as machining error in the punch plate, stripper plate, or die plate, or to guide bushing adhesive gaps. If the punch is inserted under these conditions, center deviation will cause punch deformation, resulting in punch breakage or abnormal wear. The following countermeasures can be enacted to eliminate the causes of the above trouble.

### Countermeasure

#### (I) Enlarge the punch guide bushing hole.

When the punch guide hole is enlarged, the stripper plate functions only for stripping of the work piece material. Because it loses its function as a punch guide, this renders it unsuitable for punching of thin sheets with small clearance or for use with high precision dies.

#### (II) Change the punch guide to an insert-type and make adjustments.

This allows adjustments to be made easily, but involves high costs.

#### (III) Adjust the die.

Use items such as liners and shims on the block die to prevent center deviation.

#### (IV) Use a reference pin to make adjustments.

The reference pin can be used to adjust for variations in the Loctite adhesive gap.

#### (V) Change to micro clearance for the precision of the stripper guide bushing mounting hole.

With precision dies that have no machining error, one way to prevent center deviation due to adhesive gaps is to minimize the clearance between the mounting hole and bushing. In this case, the concentricity and circularity of the bushing are critical. Use a precision grade bushing (VG·TG series). Also, the additional DRC alteration process is the optimal way to improve adhesion strength.

Another way to prevent centering deviation is to change to a press-fit bushing, however because press fitting causes strain due to the shrinkage of the internal diameter, and also has a weak mounting strength, this method is not recommended for high-precision dies.

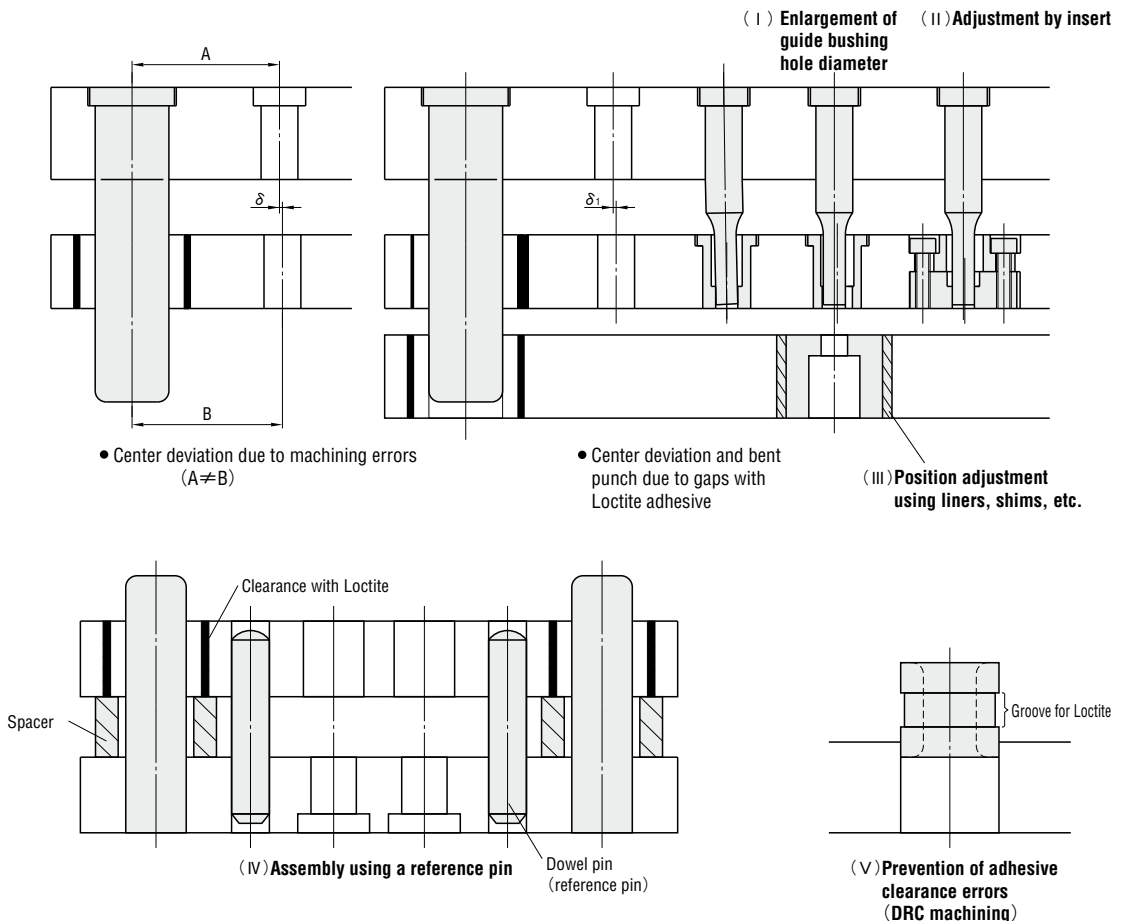

## ■ Assembling the stripper guide pin

### Headed type

- (1) Since the headed type guide pins are press fit with the sliding part as a lead, press-fit errors are minimized and perpendicularity can be easily achieved. (Fig. 1)
- (2) Ideally, the protruding head surface which protrudes above the plate surface after press fitting should be ground away, producing a surface that is level with the plate. (Fig. 2) (Since the head thickness tolerance for the TG and VG series is  $5 \begin{smallmatrix} 0 \\ -0.05 \end{smallmatrix}$ , it is possible to make adjustments at the counter bore depth. For SGPH·SGOH, the additional TKC alteration process will improve the tolerance of head thickness.)
- (3) If any gaps exist at the head, then even slight looseness during use will adversely affect the perpendicularity. (Fig. 3)

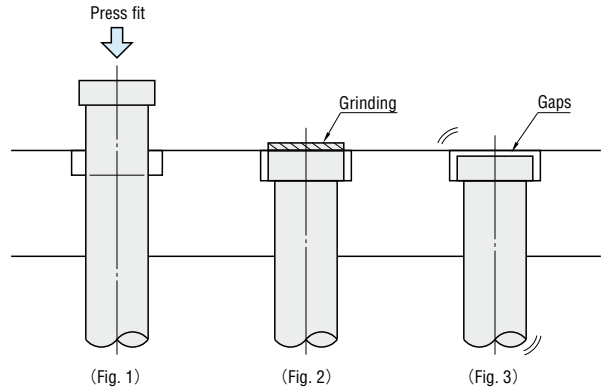

### Straight type

- (1) If a straight type guide pin is inclined when press fit during assembly, seizure may occur during sliding as a result of insufficient perpendicularity. (Fig. 4)
- (2) If a guide is used during press fitting, stable perpendicularity can be achieved. (Fig. 5)  
For bolt-type guide pins, if the guide pin end face is not maintained perpendicular, then bolt tightening will result in a perpendicularity defect. (Fig. 6)  
(For SGPN and SGON, it is possible to improve perpendicularity by the additional TGC adjustment process. The end surfaces of the TG and VG series have already been ground.)

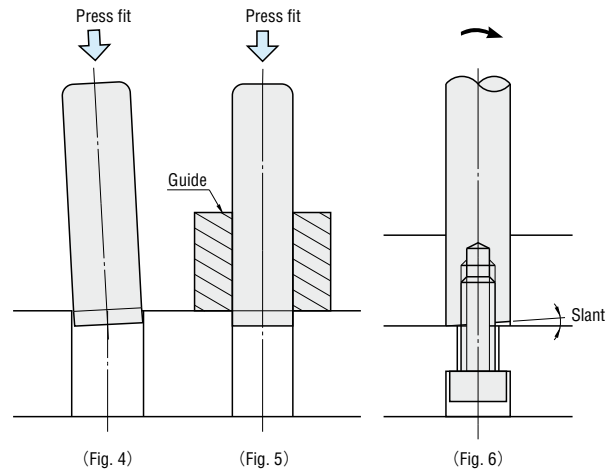

## ■ Guide length for stripper guide pins

### Press fit length of guide pin for punch plate

Thickness of 1.5~2 times the guide pin diameter is most suitable for producing perpendicularity. (Fig. 7)

$$T \geq D, \quad T = (1.5 \sim 2) D$$

### Stripper plate guide length

Thickness of 1.5~2 times the guide pin diameter is most suitable when considering stability and seizure of the guide. (Fig. 8)

$$T \geq D, \quad T = (1.5 \sim 2) D$$

