

# BLOCK DIES

## BLOCK DIES



| Product name<br>Type | BLOCK DIES |               | BLOCK DIES — SMALL TYPE — |               | SCRAP RETENTION BLOCK DIES |               |
|----------------------|------------|---------------|---------------------------|---------------|----------------------------|---------------|
|                      | Straight   | Single flange | Straight                  | Single flange | Straight                   | Single flange |
| Page                 | 469        |               | 471                       |               | 473                        |               |



| Product name<br>Type | BLOCK DIES — CONFIGURABLE SIZE TYPE — |     | SCRAP RETENTION BLOCK DIES — CONFIGURABLE SIZE TYPE — |     | BLOCK DIES — FIXING-BOLT TYPE — |     | SCRAP RETENTION BLOCK DIES — FIXING-BOLT TYPE — |     |
|----------------------|---------------------------------------|-----|---|-----|---------------------------------|-----|---|-----|
|                      | Page                                  | 475 |   | 477 |                                 | 479 |   | 481 |



| Product name<br>Type | BLOCK DIE BLANKS |               | BLOCK DIE BLANKS — FIXING-BOLT TYPE — |               | SPACERS — FOR BLOCK DIE — |               |
|----------------------|------------------|---------------|---------------------------------------|---------------|---------------------------|---------------|
|                      | Straight         | Single flange | Straight                              | Single flange | Straight                  | Single flange |
| Page                 | 483              |               | 484                                   |               | 485                       |               |

### How to order block dies

The position of the shaped hole can be determined as needed within the allowable range.



Order

(1) If shaped hole is at center of shank

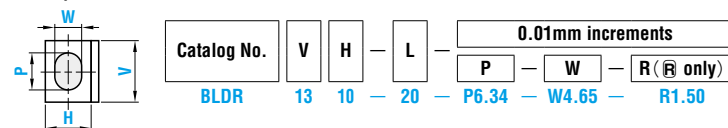

(2) If shaped hole is not at center of shank

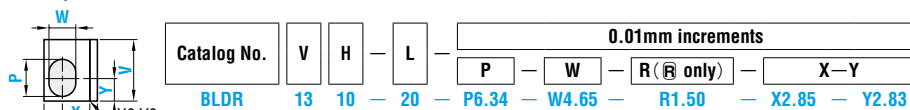

The position of the shaped hole center is determined by X and Y.  
Unit: 0.01 increment  
Tolerance: X, Y ± 0.005 (Shaped holes A), X, Y ± 0.01 (Shaped holes B, C, D)  
Range: Refer below.

For a scrap retention block die, only hole shapes A can be selected.

X, Y range: X and Y values can be determined as needed as long as the shaped hole does not contact the area shown in the figure below.

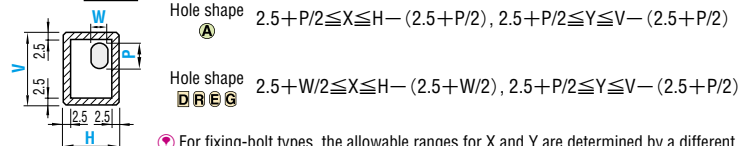

For fixing-bolt types, the allowable ranges for X and Y are determined by a different formula from the above. Refer to the corresponding product page.

Be aware that the shaped hole position and X/Y values are determined differently for block punches.

# BLOCK DIES — GUIDE —

## Block dies list

| Block die type                   | M                   | Type         | Without scrap retention |         |       | With scrap retention |           |       |
|----------------------------------|---------------------|--------------|-------------------------|---------|-------|----------------------|-----------|-------|
|                                  |                     |              | Round                   | Shaped  | Page  | Round                | Shaped    | Page  |
| Block, straight                  | Equivalent to SKD11 | Regular type | BLD                     | BLD□    | P.469 | SR-BLD               | SR-BLD□   | P.473 |
|                                  |                     |              | PBLD                    | PBLD□   |       | SR-PBLD              | SR-PBLD□  |       |
| Block, single flange             | Equivalent to SKD11 | Regular type | BLDF                    | BLD□F   | P.469 | SR-BLDF              | SR-BLD□F  | P.473 |
|                                  |                     |              | PBLDF                   | PBLD□F  |       | SR-PBLDF             | SR-PBLD□F |       |
| Block, straight, small type      | Equivalent to SKD11 | Regular type | SBLD                    | SBLD□   | P.471 |                      |           |       |
|                                  |                     |              | SPBLD                   | SPBLD□  |       |                      |           |       |
| Block, single flange, small type | Equivalent to SKD11 | Regular type | SBLDF                   | SBLD□F  | P.471 |                      |           |       |
|                                  |                     |              | SPBLDF                  | SPBLD□F |       |                      |           |       |
| Block, configurable size         | Equivalent to SKD11 | Regular type | FBLD                    | FBLD□   | P.475 | SR-FBLD              | SR-FBLD□  | P.477 |
|                                  |                     |              | FPBLD                   | FPBLD□  |       | SR-FPBLD             | SR-FPBLD□ |       |
| Block, fixing-bolt               | Equivalent to SKD11 | Regular type | BBD                     | BBD□    | P.479 | SR-BBD               | SR-BBD□   | P.481 |
|                                  |                     |              |                         |         |       |                      |           |       |

### Indication of block die relief angle

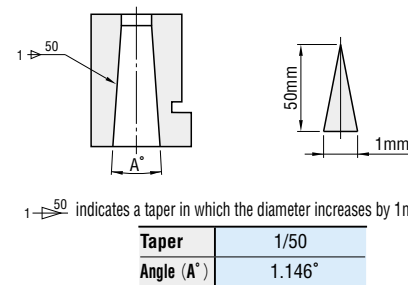

### Dimension L of block die and spread of dimensions P and W (α × 2) In case of

(α × 2) part dimension: Spread of P·W (when B=2).  
Values in the table below are values for the α part on each side.

| L  | 2α   |
|----|------|
| 16 | 0.28 |
| 20 | 0.36 |
| 22 | 0.40 |
| 25 | 0.46 |
| 30 | 0.56 |
| 35 | 0.66 |

If used with LC,  $2\alpha = \frac{LC-B}{50}$ .

### Scrap retention block dies (For details, see P.1619)

Scrap retention block dies include two or more slanted grooves machined on the inner surface of the die. The scrap initially punched out during the punching process forms small projections along the slanted grooves in the die. When the punching process pushes this scrap farther down to the bottom, the projections become compressed by the sides of the die ("ironing" effect), preventing scrap lifting from occurring.

#### Applicable range



- Hole diameter:  $\phi 1.0 \sim \phi 16$
- Workpiece material: Can be used for materials with tensile strengths up to 1,177N/mm<sup>2</sup> (120kgf/mm<sup>2</sup>)
- Thickness of workpiece materials: Minimum thickness 0.15 mm
- The scrap retention effect cannot be obtained if the clearance (C) exceeds 20% of the workpiece thickness (MT). Make sure that the clearance is 20% or less of MT.  
Clearance (C) < Workpiece thickness (MT) × 20%

Because scrap retention block dies prevent scrap lifting by forming small projections on punching scrap, they are not suitable in cases such as punching of precision holes, or when the punched-out item becomes the product.

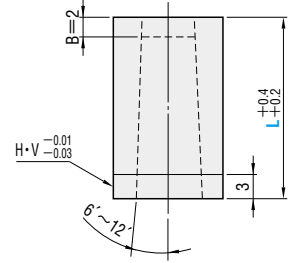

# BLOCK DIES

## —SMALL TYPE—

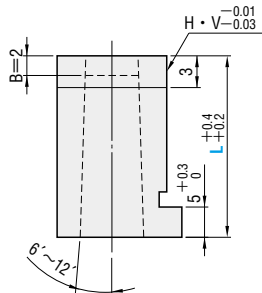
|                 |   |      |        |             |  |  |
|-----------------|---|------|--------|-------------|--|--|
| —Straight—      |  | RoHS | M<br>H | Catalog No. |  |  |
|                 |   |      |        | A           | D R E G                                  |  |
|                 |   |      |        | SBLD        | SBLDD<br>SBLDR<br>SBLDE<br>SBLDG         |  |
|                 |   |      |        | SPBLD       | SPBLDD<br>SPBLDR<br>SPBLDE<br>SPBLDG     |  |
| —Single flange— |  | RoHS | M<br>H | Catalog No. |  |  |
|                 |   |      |        | A           | D R E G                                  |  |
|                 |   |      |        | SBLDF       | SBLDDF<br>SBLDRF<br>SBLDEF<br>SBLDGF     |  |
|                 |   |      |        | SPBLDF      | SPBLDDF<br>SPBLDRF<br>SPBLDEF<br>SPBLDGF |  |

|   |   |   |   |   |
|---|---|---|---|---|
| Hole shape  | Hole shape  | Hole shape  | Hole shape  | Hole shape  |
|  |  |  |  |  |
| W min. ≤ P ≤ W max.<br>P dimension must be within the range of W dimension.         | P ≥ W   | P ≥ W<br>0.15 ≤ R < W/2   | P > W   | P > W   |

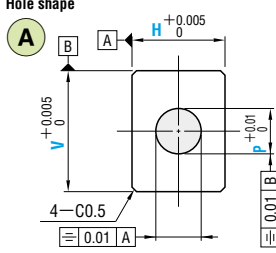
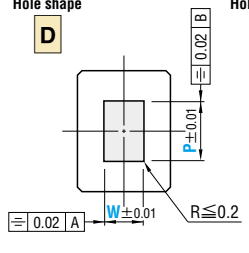
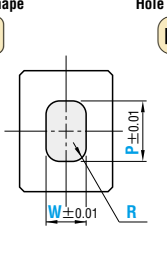
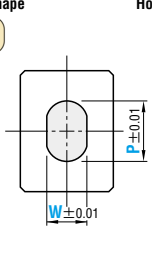
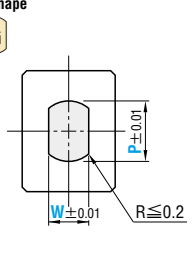
|   |   |   |   |   |
|---|---|---|---|---|
| Hole shape  | Hole shape  | Hole shape  | Hole shape  | Hole shape  |
|  |  |  |  |  |
| W min. ≤ P ≤ W max.<br>P dimension must be within the range of W dimension.         | P ≥ W   | P ≥ W<br>0.15 ≤ R < W/2   | P > W   | P > W   |

| Catalog No.        | H | V      |        |        | R | L  |
|--------------------|---|--------|--------|--------|---|----|
|                    |   | min. W | min. P | max. P |   |    |
| Straight           | 3 | 0.60   | 0.60   | 0.60   | R | 10 |
|                    |   | 1.00   | 2.00   | 3.00   |   |    |
| Single flange type | 4 |        |        |        | R | 13 |
|                    | 5 |        |        |        | R | 16 |
|                    |   |        |        |        | R | 20 |
|                    |   |        |        |        |   | 22 |
|                    |   |        |        |        |   | 25 |

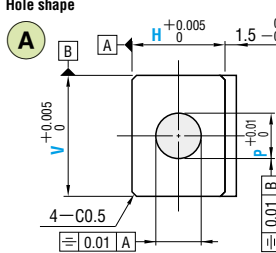
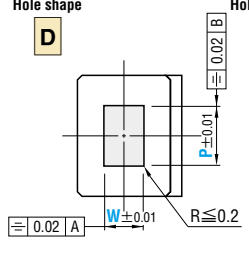
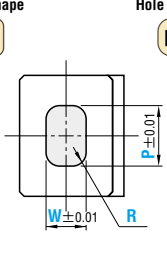
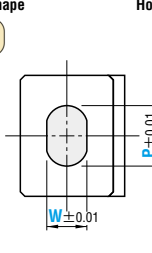
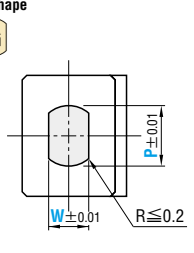
Ⓜ P·W·R→0.01mm increments    Ⓜ For single flange types, if L=10 then press-in lead is not included.

Order  Catalog No. V H L — 0.01mm increments — P — W — R (R only)

SBLD 03 03 — 20 — P0.60

Price  **Quotation**

Days to Ship  **Quotation**

Alterations  Catalog No. V H L(LC) — P—W—R — (BC-HC, etc.)

SBLDF 04 04 — LC15.5 — P1.85 — TKC

| Alteration                 | Code | A  | D R E G  | 1Code            |
|----------------------------|------|--|--|------------------|
| Alterations to shaped hole | BC   | Shaped hole depth change<br>0 ≤ BC ≤ 2<br>0.1mm increments   |  |                  |
|                            | PKC  | Shaped hole tolerance change<br>P +0.01 ⇄ +0.005<br>0 ⇄ 0  | Shaped hole tolerance change<br>P - W ± 0.01 ⇄ +0.01<br>0  | <b>Quotation</b> |
|                            | HVC  |  | H and V are reversed relative to shaped hole. P dimension is machined in direction H and W dimension is machined in direction V.<br>Ⓜ P ≤ W max. |                  |
| Alterations to full length | LC   | Full length change<br>10 ≤ LC < L<br>0.1mm increments<br>(If combined with LKC·LKZ, 0.01mm increments can be selected.)<br>Ⓜ For single flange types, if LC ≤ 12 then press-in lead is not included. |  |                  |
|                            | LKC  | Full length tolerance change   | L +0.4<br>+0.2 ⇄ +0.05<br>0  |                  |
|                            | LKZ  | Full length tolerance change   | L +0.4<br>+0.2 ⇄ +0.01<br>0  |                  |

| Alteration            | Code                              | A   | D R E G                               | 1Code            |
|-----------------------|-----------------------------------|---|---------------------------------------|------------------|
| Alterations to flange | HC                                | Flange width change<br>0 ≤ HC < 1.5<br>0.1mm increments   |                                       |                  |
|                       | TC                                | Flange thickness change<br>2 ≤ TC < 5<br>0.1mm increments (If combined with TKC·TKM, 0.01mm increments can be selected.)<br>Ⓜ Full length is shortened by (5-TC).<br>If combined with LC, full length is equal to LC. |                                       | <b>Quotation</b> |
|                       | TKC                               | Flange thickness tolerance change   | T +0.3<br>0 ⇄ +0.02<br>0              |                  |
| TKM                   | Flange thickness tolerance change | T +0.3<br>0 ⇄ -0.02<br>0  |                                       |                  |
| Others                | VHM                               | Shape tolerance change  | H·V +0.005<br>0 ⇄ -0.005              |                  |
|                       | NDC                               |   | H·V -0.01<br>-0.03 ⇄ No press-in lead |                  |

# SCRAP RETENTION BLOCK DIES



| —Straight—                           | RoHS                           | M<br>H   | Catalog No. |         | Diagram |
|--------------------------------------|--------------------------------|----------|-------------|---------|---------|
|                                      |                                |          | A           | D R E G |         |
|                                      | Equivalent to SKD11 60 ~ 63HRC | SR-BLD   | SR-BLDD     | SR-BLDR |         |
|                                      |                                |          | SR-BLDE     | SR-BLDG |         |
| Powdered high-speed steel 64 ~ 67HRC | SR-PBLD                        | SR-PBLDD | SR-PBLDR    |         |         |
|                                      |                                | SR-PBLDE | SR-PBLDG    |         |         |

| —Single flange—                      | RoHS                           | M<br>H    | Catalog No. |          | Diagram |
|--------------------------------------|--------------------------------|-----------|-------------|----------|---------|
|                                      |                                |           | A           | D R E G  |         |
|                                      | Equivalent to SKD11 60 ~ 63HRC | SR-BLDF   | SR-BLDDF    | SR-BLDRF |         |
|                                      |                                |           | SR-BLDEF    | SR-BLDGF |         |
| Powdered high-speed steel 64 ~ 67HRC | SR-PBLDF                       | SR-PBLDDF | SR-PBLDRF   |          |         |
|                                      |                                | SR-PBLDEF | SR-PBLDGF   |          |         |

| Catalog No.   | H  | V            |              | R    |      |      |      |      |      |      |    | L   | MT<br>(workpiece material thickness)<br>0.01mm increments | C<br>(clearance)<br>0.005mm increments |
|---------------|----|--------------|--------------|------|------|------|------|------|------|------|----|---|---|--|
|               |    | min. P max.  | min. W max.  | 6    | 8    | 10   | 13   | 16   | 20   | 25   |    |   |   |  |
| Straight      | 6  | 1.00 ~ 3.00  | 1.00 ~ 3.00  | 1.00 | 1.00 | 1.00 | 1.00 | 1.00 | 1.50 | 1.50 | 16 | MT ≥ 0.15<br>Select a workpiece material thickness of 0.15mm or more. | C ≥ 0.010<br>Select a clearance of 0.010mm or more.       |  |
| Single flange | 8  | 1.00 ~ 4.00  | 1.00 ~ 4.00  | 1.00 | 1.00 | 1.00 | 1.00 | 1.00 | 1.50 | 1.50 | 20 |   |   |  |
| A SR-BLD      | 10 | 1.00 ~ 6.00  | 1.00 ~ 6.00  | 1.00 | 1.00 | 1.00 | 1.00 | 1.00 | 1.50 | 1.50 | 25 |   |   |  |
| D SR-BLDD     | 13 | 1.00 ~ 8.00  | 1.00 ~ 8.00  | 1.00 | 1.00 | 1.00 | 1.00 | 1.00 | 1.50 | 1.50 | 30 |   |   |  |
| R SR-BLDR     | 16 | 1.00 ~ 10.00 | 1.00 ~ 10.00 | 1.00 | 1.00 | 1.00 | 1.00 | 1.00 | 1.50 | 1.50 | 35 |   |   |  |
| E SR-BLDE     | 20 | 1.50 ~ 12.00 | 1.50 ~ 12.00 | 1.00 | 1.00 | 1.00 | 1.00 | 1.00 | 1.50 | 1.50 | 35 |   |   |  |
| G SR-BLDG     | 25 | 1.50 ~ 16.00 | 1.50 ~ 16.00 | 1.00 | 1.00 | 1.00 | 1.00 | 1.00 | 1.50 | 1.50 | 35 | 0.15 ≤ R < W/2 (R only)   |   |  |

P·W·R...0.01mm increments    Can be used only for workpiece materials with tensile strengths up to 1,177N/mm<sup>2</sup> (120kgf/mm<sup>2</sup>).  
 Workpiece material thickness and clearance are used as machining data for the scrap retention. Specify the shaped hole dimensions (P·W·R) when selecting the block die finishing dimensions.

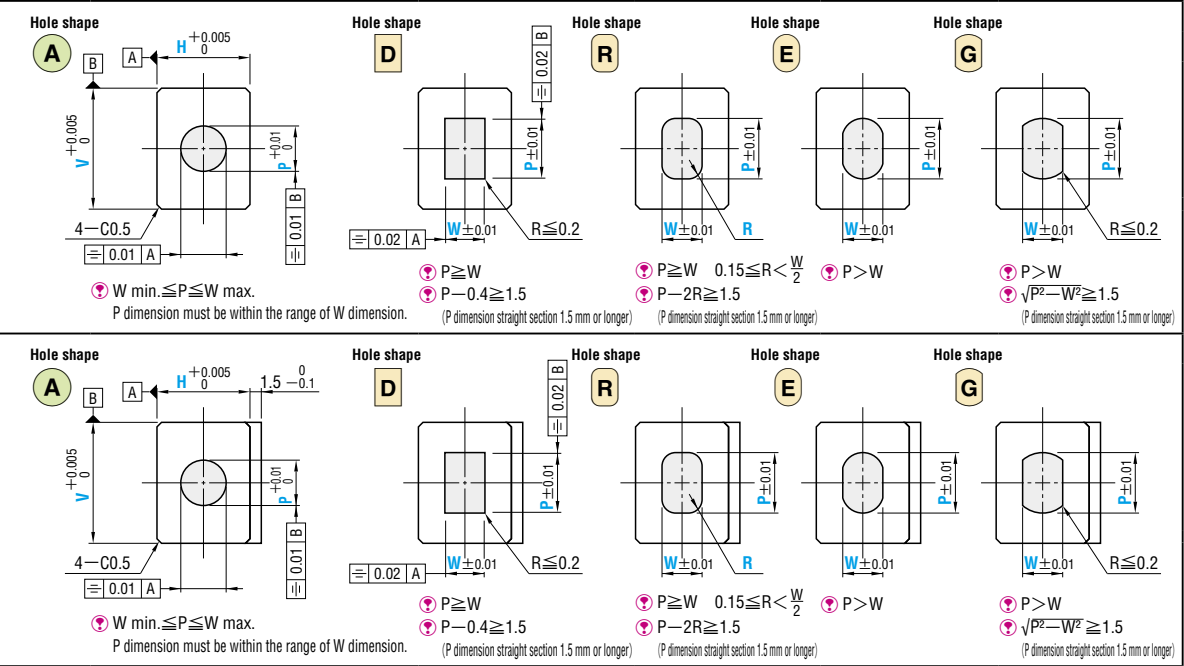

**Order**

(1) If shaped hole is at center of shank

Catalog No. V H - L - P - W - R (R only) - MT - C

SR-PBLDRF 13 10 - 22 - P7.65 - W3.65 - R0.50 - MT1.50 - C0.105

(2) If shaped hole is not at center of shank (hole shapes A only)

Catalog No. V H - L - P - MT - C - X - Y

SR-PBLDF 13 10 - 22 - P4.35 - MT1.50 - C0.105 - X4.85 - Y7.82

For the upper and lower limit values for X and Y, refer to P.467.  
 X, Y tolerance: ±0.005  
 Be aware that the shaped hole position and X/Y values are determined differently for block punches.

**Alterations**

Catalog No. V H - L(LC) - P - W - R - MT - C - (BC-HC, etc.)

SR-BLDF 08 06 - LC21 - P2.25 - MT1.50 - C0.105 - LKC - ANF1.2

**P** Price **Quotation**

**Days to Ship** **Quotation**

| Alteration                 | Code | A  | D R E G  | 1Code     |
|----------------------------|------|--|--|-----------|
| Alterations to shaped hole | BC   | Shaped hole depth change<br>1 ≤ BC ≤ B max.<br>0.1mm increments  | Shaped hole depth change<br>1 ≤ BC < 2<br>0.1mm increments | Quotation |
|                            | PKC  | Shaped hole tolerance change<br>P +0.01 ⇨ +0.005<br>0  | Shaped hole tolerance change<br>P·W ±0.01 ⇨ ±0.01<br>0     |           |
|                            | HVC  | H and V are reversed relative to shaped hole. P dimension is machined in direction H and W dimension is machined in direction V.<br>P ≤ W max.<br>P dimension must be within the range of W dimension listed in the specification table. |  |           |
| Alterations to flange      | HC   | Flange width change<br>0 ≤ HC < 1.5<br>0.1mm increments  |  |           |
|                            | TC   | Flange thickness change<br>0.1mm increments (if combined with TKC·TKM, 0.01mm increments can be selected.)<br>Full length is shortened by (S-TC).<br>If combined with LC, full length is equal to LC.                                    |  |           |
|                            | TKC  | Flange thickness tolerance change  | T +0.3 ⇨ +0.02<br>0  |           |
|                            | TKM  | Flange thickness tolerance change  | T +0.3 ⇨ 0<br>0 -0.02                                      |           |

| Alteration                 | Code | A   | D R E G   | 1Code     |
|----------------------------|------|---|---|-----------|
| Alterations to full length | LC   | Full length change<br>10 ≤ LC < L<br>0.1mm increments<br>(if combined with LKC-LKZ, 0.01mm increments can be selected.)<br>For single flange types, if LC ≤ 12 then press-in lead is not included.              |   |           |
|                            | LKC  | Full length tolerance change  | L +0.4 ⇨ +0.05<br>+0.2 0  |           |
|                            | LKZ  | Full length tolerance change  | L +0.4 ⇨ +0.01<br>+0.2 0  |           |
| Others                     | VHM  | Shape tolerance change  | H·V +0.005 ⇨ 0<br>-0.005  | Quotation |
|                            | ANF  | Angular angle change<br>0 ≤ ANF ≤ 1.2<br>0.2° increments<br>d ≤ dmax.<br>d = P + 2((L-B) tan(ANF°))<br>P - Btan(ANF°) ≥ 0.6<br>W - Btan(ANF°) ≥ 0.6<br>Cannot be used if shaped hole is not at center of shank. | H·V -0.01 ⇨ 0<br>-0.03<br>Taper 1/50<br>Angle (one side) 0.573° |           |

# BLOCK DIES

— CONFIGURABLE SIZE TYPE —

— Straight —

RoHS

| M                                       | Catalog No. |                                      |
|---|-------------|--------------------------------------|
|   | A           | D R E G                              |
| Equivalent to SKD11<br>60 ~ 63HRC       | FBLD        | FBLDD<br>FBLDR<br>FBLDE<br>FBLDG     |
| Powdered high-speed steel<br>64 ~ 67HRC | FPBLD       | FPBLDD<br>FPBLDR<br>FPBLDE<br>FPBLDG |

Hole shape A

W min. ≤ P ≤ W max.  
P dimension must be within the range of W dimension.

Hole shape D

P ≥ W

Hole shape R

P ≥ W  
0.15 ≤ R < W/2

Hole shape E

P > W

Hole shape G

P > W

| Catalog No.                                       | H           | V            |               | min. P max. | V   |     |      |      |      |      |                         | R                                | L |
|---|-------------|--------------|---------------|-------------|-----|-----|------|------|------|------|-------------------------|----------------------------------|---|
|   |             | min. W max.  | a min. b min. |             | 6.0 | 8.1 | 10.1 | 13.1 | 16.1 | 20.1 |                         |                                  |   |
| (Equivalent to SKD11) (Powdered high-speed steel) | 6.0 ~ 8.0   | 1.00 ~ 6.00  | 4             | 4.00        | 4   | 4   | 5    | 6    | 8    | 9    | 0.15 ≤ R < W/2 (R only) | 16<br>20<br>22<br>25<br>30<br>35 |   |
| <b>A</b> FBLD FPBLD                               | 8.1 ~ 10.0  | 1.00 ~ 6.00  | 4             | 6.00        |     |     |      |      |      |      |                         |                                  |   |
| <b>D</b> FBLDD FPBLDD                             | 10.1 ~ 13.0 | 1.00 ~ 8.00  | 5             | 8.00        |     |     |      |      |      |      |                         |                                  |   |
| <b>R</b> FBLDR FPBLDR                             | 13.1 ~ 16.0 | 1.00 ~ 10.00 | 6             | 10.00       |     |     |      |      |      |      |                         |                                  |   |
| <b>E</b> FBLDE FPBLDE                             | 16.1 ~ 20.0 | 1.50 ~ 12.00 | 8             | 12.00       |     |     |      |      |      |      |                         |                                  |   |
| <b>G</b> FBLDG FPBLDG                             | 20.1 ~ 25.0 | 1.50 ~ 16.00 | 9             | 16.00       |     |     |      |      |      |      |                         |                                  |   |

Ⓜ V—P=a H—W=b (For shape A, H—P=b)  
 Ⓜ P·W·R→0.01mm increments V·H→0.1mm increments



**Order**

(1) If shaped hole is at center of shank

Catalog No. — [0.1mm increments] V — [0.1mm increments] H — [0.1mm increments] L — [0.01mm increments] P — [0.01mm increments] W — [0.01mm increments] R (R only)

FBLDE — V15.8 — H12.8 — L22 — P7.25 — W5.75

(2) If shaped hole is not at center of shank

Catalog No. — [0.1mm increments] V — [0.1mm increments] H — [0.1mm increments] L — [0.01mm increments] P — [0.01mm increments] W — [0.01mm increments] R (R only) — [0.01mm increments] X—Y

FBLDE — V15.8 — H12.8 — L22 — P7.25 — W5.75 — X5.80 — Y8.35

Ⓜ For the upper and lower limit values for X and Y, refer to P.467.  
 Ⓜ X,Y tolerance: ±0.005 (Shaped holes A), ±0.01 (Shaped holes D R E G)  
 Ⓜ Be aware that the shaped hole position and X/Y values are determined differently for block punches.



**Quotation**

Days to Ship **Quotation**

Alterations Catalog No. — V — H — L(LC) — P—W—R — (BC·LKC, etc.)

FBLDD — V12.5 — H9.5 — LC28.5 — P6.25 — W4.75 — LKC — ANF1.2

| Alteration                 | Code | A  | D R E G   | 1Code            |
|----------------------------|------|--|---|------------------|
| Alterations to shaped hole | BC   | Shaped hole depth change<br>0 ≤ BC ≤ 4<br>0.1mm increments   | —   |                  |
|                            | PKC  | Shaped hole tolerance change<br>P +0.01 ↗ +0.005 ↘<br>0  | Shaped hole tolerance change<br>P·W ±0.01 ↗ +0.01 ↘<br>0  |                  |
|                            | HVC  | —  | H and V are reversed relative to shaped hole. P dimension is machined in direction H and W dimension is machined in direction V.<br>Ⓜ P ≤ W max.<br>P dimension must be within the range of W dimension listed in the specification table.<br>Ⓜ Cannot be used if shaped hole is not at center. | <b>Quotation</b> |
| Alterations to full length | LC   | Full length change<br>10 ≤ LC < L<br>0.1mm increments (If combined with LKC·LKZ, 0.01mm increments can be selected.) | —   |                  |
|                            | LKC  | Full length tolerance change<br>L +0.4 ↗ +0.05 ↘<br>+0.2 0   | —   |                  |
|                            | LKZ  | Full length tolerance change<br>L +0.4 ↗ +0.01 ↘<br>+0.2 0   | —   |                  |

| Alteration  | Code   | A   | D R E G  | 1Code |        |           |     |            |     |             |     |             |     |             |      |             |      |             |      |
|-------------|--------|---|--|-------|--------|-----------|-----|------------|-----|-------------|-----|-------------|-----|-------------|------|-------------|------|-------------|------|
| Others      | VHM    | Shape tolerance change<br>H·V +0.005 ↗ 0 ↘<br>0 -0.005  | —  |       |        |           |     |            |     |             |     |             |     |             |      |             |      |             |      |
|             | NDC    | No press-in lead  | —  |       |        |           |     |            |     |             |     |             |     |             |      |             |      |             |      |
|             | ANF    | Angular angle change<br>0 ≤ ANF ≤ 1.2<br>0.2° increments<br>Ⓜ d ≤ dmax.<br>Ⓜ d = P + 2((L-B) tan(ANF°))<br>Ⓜ P - Btan(ANF°) ≥ 0.6<br>Ⓜ W - Btan(ANF°) ≥ 0.6<br>Ⓜ Cannot be used if shaped hole is not at center of shank. | <table border="1"> <tr> <th>V</th> <th>d max.</th> </tr> <tr> <td>6.0 ~ 8.0</td> <td>3.4</td> </tr> <tr> <td>8.0 ~ 10.0</td> <td>4.4</td> </tr> <tr> <td>10.0 ~ 13.0</td> <td>6.4</td> </tr> <tr> <td>13.0 ~ 16.0</td> <td>8.4</td> </tr> <tr> <td>16.0 ~ 20.0</td> <td>10.6</td> </tr> <tr> <td>20.0 ~ 25.0</td> <td>12.6</td> </tr> <tr> <td>25.0 ~ 35.0</td> <td>14.6</td> </tr> </table> | V     | d max. | 6.0 ~ 8.0 | 3.4 | 8.0 ~ 10.0 | 4.4 | 10.0 ~ 13.0 | 6.4 | 13.0 ~ 16.0 | 8.4 | 16.0 ~ 20.0 | 10.6 | 20.0 ~ 25.0 | 12.6 | 25.0 ~ 35.0 | 14.6 |
| V           | d max. |   |  |       |        |           |     |            |     |             |     |             |     |             |      |             |      |             |      |
| 6.0 ~ 8.0   | 3.4    |   |  |       |        |           |     |            |     |             |     |             |     |             |      |             |      |             |      |
| 8.0 ~ 10.0  | 4.4    |   |  |       |        |           |     |            |     |             |     |             |     |             |      |             |      |             |      |
| 10.0 ~ 13.0 | 6.4    |   |  |       |        |           |     |            |     |             |     |             |     |             |      |             |      |             |      |
| 13.0 ~ 16.0 | 8.4    |   |  |       |        |           |     |            |     |             |     |             |     |             |      |             |      |             |      |
| 16.0 ~ 20.0 | 10.6   |   |  |       |        |           |     |            |     |             |     |             |     |             |      |             |      |             |      |
| 20.0 ~ 25.0 | 12.6   |   |  |       |        |           |     |            |     |             |     |             |     |             |      |             |      |             |      |
| 25.0 ~ 35.0 | 14.6   |   |  |       |        |           |     |            |     |             |     |             |     |             |      |             |      |             |      |

BLOCK DIES

# SCRAP RETENTION BLOCK DIES

—CONFIGURABLE SIZE TYPE—



—Straight— RoHS

|   |                 |  |
|---|-----------------|--|
| Equivalent to SKD11<br>60 ~ 63HRC       | Catalog No.     |  |
|   | <b>A</b>        | <b>D R E G</b>   |
| Powdered high-speed steel<br>64 ~ 67HRC | <b>SR—FBLD</b>  | <b>SR—FBLDD</b><br><b>SR—FBLDR</b><br><b>SR—FBLDE</b><br><b>SR—FBLDG</b>     |
|   | <b>SR—FPBLD</b> | <b>SR—FPBLDD</b><br><b>SR—FPBLDR</b><br><b>SR—FPBLDE</b><br><b>SR—FPBLDG</b> |

Hole shape **A** **D** **R** **E** **G**

- A**:  $H+0.005$ ,  $4-C0.5$ ,  $P+0.01$ ,  $V+0.005$ ,  $W \min. \leq P \leq W \max.$ , P dimension must be within the range of W dimension.
- D**:  $0.02$ ,  $W \pm 0.01$ ,  $R \leq 0.2$ ,  $P \geq W$ ,  $P-0.4 \geq 1.5$  (Straight portion of P dimension must be 1.5mm or longer).
- R**:  $0.02$ ,  $W \pm 0.01$ ,  $R \leq 0.2$ ,  $P \geq W$ ,  $0.15 \leq R < \frac{W}{2}$ ,  $P-2R \geq 1.5$  (Straight portion of P dimension must be 1.5mm or longer).
- E**:  $0.02$ ,  $W \pm 0.01$ ,  $R \leq 0.2$ ,  $P > W$ .
- G**:  $0.02$ ,  $W \pm 0.01$ ,  $R \leq 0.2$ ,  $P > W$ ,  $\sqrt{P^2 - W^2} \geq 1.5$  (Straight portion of P dimension must be 1.5mm or longer).

| Catalog No.                                       | H           | V            |             | R    |      |      |      |      |      | R                       | L  | MT<br>(workpiece material thickness)<br>0.01mm increments             | C<br>(clearance)<br>0.005mm increments              |
|---|-------------|--------------|-------------|------|------|------|------|------|------|-------------------------|----|---|---|
|   |             | min. W max.  | min. P max. | 4    | 8.1  | 10.1 | 13.1 | 16.1 | 20.1 |                         |    |   |   |
| (Equivalent to SKD11) (Powdered high-speed steel) | 6.0 ~ 8.0   | 1.00 ~ 4.00  | 4           | 1.00 | 1.00 | 1.00 | 1.00 | 1.50 | 1.50 | 0.15 ≤ R < W/2 (R only) | 16 | MT ≥ 0.15   | C ≥ 0.010   |
| <b>A</b> SR—FBLD SR—FPBLD                         | 8.1 ~ 10.0  | 1.00 ~ 6.00  | 4           | 1.00 | 1.00 | 1.00 | 1.00 | 1.50 | 1.50 | 0.15 ≤ R < W/2 (R only) | 20 | Select a workpiece material thickness of 0.15mm or more.<br>Clearance | Select a clearance of 0.010mm or more.<br>Clearance |
| <b>D</b> SR—FBLDD SR—FPBLDD                       | 10.1 ~ 13.0 | 1.00 ~ 8.00  | 5           |      |      |      |      |      |      |                         | 22 |   |   |
| <b>R</b> SR—FBLDR SR—FPBLDR                       | 13.1 ~ 16.0 | 1.00 ~ 10.00 | 6           |      |      |      |      |      |      |                         | 25 |   |   |
| <b>E</b> SR—FBLDE SR—FPBLDE                       | 16.1 ~ 20.0 | 1.50 ~ 12.00 | 8           |      |      |      |      |      |      |                         | 30 |   |   |
| <b>G</b> SR—FBLDG SR—FPBLDG                       | 20.1 ~ 25.0 | 1.50 ~ 16.00 | 9           |      |      |      |      |      |      |                         | 35 |   |   |

- $V = P = a$   $H = W = b$  (For shape **A**,  $H = P = b$ )
- $P \cdot W \cdot R \rightarrow 0.01\text{mm}$  increments  $V \cdot H \rightarrow 0.1\text{mm}$  increments
- Can be used only for workpiece materials with tensile strengths up to 1,177N/mm<sup>2</sup> (120kgf/mm<sup>2</sup>).
- Workpiece material thickness and clearance are used as machining data for the scrap retention. Specify the shaped hole dimensions (P·W·R) when selecting the block die finishing dimensions.

Days to Ship Quotation

Alterations Catalog No. — V — H — L(LC) — P—W—R — MT — C — (BC·LKC, etc.)  
SR—FBLDD — V12.5 — H9.5 — LC28 — P6.25—W4.75 — MT1.50 — C0.105 — LKC — ANF1.2

| Alteration                 | Code       | <b>A</b>   | <b>D R E G</b>   | 1Code   |
|----------------------------|------------|--|--|---|
| Alterations to shaped hole | <b>BC</b>  | Shaped hole depth change<br>$1 \leq BC \leq B \max.$<br>0.1mm increments<br>$\frac{P}{B \max.}$<br>1.00 ~ 1.99<br>2.00 ~ 4   | Shaped hole depth change<br>$1 \leq BC < 2$<br>0.1mm increments                                      | <span style="border: 1px solid black; padding: 2px;">Quotation</span> |
|                            | <b>PKC</b> | Shaped hole diameter tolerance change<br>$P + 0.01 \rightarrow +0.005$<br>$0 \rightarrow 0$  | Shaped hole diameter tolerance change<br>$P \cdot W \pm 0.01 \rightarrow +0.01$<br>$0 \rightarrow 0$ |   |
|                            | <b>HVC</b> | H and V are reversed relative to shaped hole. P dimension is machined in direction H and W dimension is machined in direction V.<br>$P \leq W \max.$<br>P dimension must be within the range of dimension W listed in the specification table. |  |   |
| Alterations to full length | <b>LC</b>  | Full length change<br>$10 \leq LC < L$<br>0.1mm increments (If combined with LKC·LKZ, 0.01mm increments can be selected.)  |  |   |
|                            | <b>LKC</b> | Full length tolerance change<br>$L + 0.4 \rightarrow +0.05$<br>$+0.2 \rightarrow 0$  |  |   |
|                            | <b>LKZ</b> | Full length tolerance change<br>$L + 0.4 \rightarrow +0.01$<br>$+0.2 \rightarrow 0$  |  |   |

| Alteration  | Code       | <b>A</b>   | <b>D R E G</b>   | 1Code   |   |        |           |  |           |  |            |  |            |  |             |  |             |  |
|-------------|------------|--|--|---|---|--------|-----------|--|-----------|--|------------|--|------------|--|-------------|--|-------------|--|
| Others      | <b>VHM</b> | Shape tolerance change<br>$H \cdot V + 0.005 \rightarrow 0$<br>$0 \rightarrow -0.005$  |  | <span style="border: 1px solid black; padding: 2px;">Quotation</span> |   |        |           |  |           |  |            |  |            |  |             |  |             |  |
|             | <b>NDC</b> | No press-in lead   |  |   |   |        |           |  |           |  |            |  |            |  |             |  |             |  |
|             | <b>ANF</b> | Angular angle change<br>$0 \leq ANF \leq 1.2$<br>$0.2^\circ$ increments<br>$d \leq d \max.$<br>$d = P + 2 \cdot ((L - B) \tan(ANF^\circ))$<br>$P - B \tan(ANF^\circ) \geq 0.6$<br>$W - B \tan(ANF^\circ) \geq 0.6$<br>Cannot be used if shaped hole is not at center of shank. | <table border="1"> <tr><th>V</th><th>d max.</th></tr> <tr><td>6.0 ~ 3.4</td><td></td></tr> <tr><td>8.0 ~ 4.4</td><td></td></tr> <tr><td>10.0 ~ 6.4</td><td></td></tr> <tr><td>13.0 ~ 8.4</td><td></td></tr> <tr><td>16.0 ~ 10.6</td><td></td></tr> <tr><td>20.0 ~ 12.6</td><td></td></tr> <tr><td>25.0 ~ 14.6</td><td></td></tr> </table><br>Taper 1/50<br>App. size 0.573 |   | V | d max. | 6.0 ~ 3.4 |  | 8.0 ~ 4.4 |  | 10.0 ~ 6.4 |  | 13.0 ~ 8.4 |  | 16.0 ~ 10.6 |  | 20.0 ~ 12.6 |  |
| V           | d max.     |  |  |   |   |        |           |  |           |  |            |  |            |  |             |  |             |  |
| 6.0 ~ 3.4   |            |  |  |   |   |        |           |  |           |  |            |  |            |  |             |  |             |  |
| 8.0 ~ 4.4   |            |  |  |   |   |        |           |  |           |  |            |  |            |  |             |  |             |  |
| 10.0 ~ 6.4  |            |  |  |   |   |        |           |  |           |  |            |  |            |  |             |  |             |  |
| 13.0 ~ 8.4  |            |  |  |   |   |        |           |  |           |  |            |  |            |  |             |  |             |  |
| 16.0 ~ 10.6 |            |  |  |   |   |        |           |  |           |  |            |  |            |  |             |  |             |  |
| 20.0 ~ 12.6 |            |  |  |   |   |        |           |  |           |  |            |  |            |  |             |  |             |  |
| 25.0 ~ 14.6 |            |  |  |   |   |        |           |  |           |  |            |  |            |  |             |  |             |  |



(1) If shaped hole is at center of shank

Catalog No. — 0.1mm increments — V — H — L — 0.01mm increments — P — W — R (R only) — MT — C

SR—FBLDE — V15.8 — H12.8 — L22 — P7.27 — W5.25 — MT1.50 — C0.105

(2) If shaped hole is not at center of shank (hole shapes **A** only)

Catalog No. — 0.1mm increments — V — H — L — 0.01mm increments — P — MT — C — 0.01mm increments — X—Y

SR—FBLD — V15.8 — H12.8 — L22 — P5.25 — MT1.50 — C0.105 — X5.80 — Y6.35

- For the upper and lower limit values for X and Y, refer to P.467.
- X, Y tolerance: ±0.005
- Be aware that the shaped hole position and X/Y values are determined differently for block punches.

P Price Quotation

# BLOCK DIES

—FIXING-BOLT TYPE—

|                                |  |  |
|--------------------------------|--|--|
| Equivalent to SKD11 60 ~ 63HRC | Catalog No.  |  |
|                                | <b>A</b> BBD<br><b>D</b> BBDD<br><b>R</b> BBDR<br><b>E</b> BBDE<br><b>G</b> BBDG |  |

RoHS

**Hole shape A**

**Hole shape D**

**Hole shape R**

**Hole shape E**

**Hole shape G**

⊕ For the lift-out tap hole, use a bolt 1 size larger than the mounting bolt.

| Mounting bolt | M (Lift-out tap hole) |
|---------------|-----------------------|
| M3            | M4                    |
| M4            | M5                    |
| M6            | M8                    |
| M8            | M10                   |

⊕ If  $P \geq W$ ,  $0.15 \leq R < \frac{W}{2}$

⊕ If  $P < W$ ,  $0.15 \leq R < \frac{P}{2}$

⊗ P=W cannot be selected.

⊕ If  $P < W$ , pay particular attention to hole shape.

⊗ P=W cannot be selected.

⊕ If  $P < W$ , pay particular attention to hole shape.

| K   | Mounting bolt |      |             | J    | Catalog No. | V  | H  | L  | 0.01mm increments |              |              |              | Base unit price |      |
|-----|---------------|------|-------------|------|-------------|----|----|----|-------------------|--------------|--------------|--------------|-----------------|------|
|     | d             | h    | Size        |      |             |    |    |    | A                 | D R E G      | R            | 1 ~ 9 pieces |                 |      |
|     | min. P max.   |      | min. P max. |      |             |    |    |    | min. W max.       |              | BBD          | BBDD         |                 |      |
| 4   | 6             | 7.5  | M3          | 3    | A BBD       | 13 | 8  | 16 | 1.00 ~ 3.00       | 1.00 ~ 3.00  | 1.00 ~ 4.00  | R            | BBD             | BBDD |
|     |               |      |             | 4    |             |    |    |    |                   |              |              |              |                 |      |
|     |               |      |             | 5    |             |    |    |    |                   |              |              |              |                 |      |
|     |               |      |             | 6.5  |             |    |    |    |                   |              |              |              |                 |      |
| 5   | 8             | 8.5  | M4          | 4    | D BBDD      | 18 | 10 | 20 | 1.00 ~ 4.00       | 1.00 ~ 4.00  | 1.00 ~ 6.00  | R            | BBD             | BBDD |
|     |               |      |             | 5    |             |    |    |    |                   |              |              |              |                 |      |
|     |               |      |             | 6.5  |             |    |    |    |                   |              |              |              |                 |      |
|     |               |      |             | 8    |             |    |    |    |                   |              |              |              |                 |      |
| 6.5 | 11            | 10.5 | M6          | 5    | R BBDR      | 20 | 13 | 22 | 1.00 ~ 6.00       | 1.00 ~ 6.00  | 1.00 ~ 9.00  | R            | BBD             | BBDD |
|     |               |      |             | 6.5  |             |    |    |    |                   |              |              |              |                 |      |
|     |               |      |             | 8    |             |    |    |    |                   |              |              |              |                 |      |
|     |               |      |             | 10   |             |    |    |    |                   |              |              |              |                 |      |
| 8   | 14            | 12.5 | M8          | 8    | E BBDE      | 22 | 16 | 25 | 1.00 ~ 12.00      | 1.00 ~ 12.00 | 1.00 ~ 12.00 | R            | BBD             | BBDD |
|     |               |      |             | 10   |             |    |    |    |                   |              |              |              |                 |      |
|     |               |      |             | 12.5 |             |    |    |    |                   |              |              |              |                 |      |
|     |               |      |             | 15   |             |    |    |    |                   |              |              |              |                 |      |
| 8   | 14            | 12.5 | M8          | 10   | G BBDG      | 25 | 20 | 35 | 1.50 ~ 16.00      | 1.50 ~ 16.00 | 1.50 ~ 16.00 | R            | BBD             | BBDD |
|     |               |      |             | 12.5 |             |    |    |    |                   |              |              |              |                 |      |
|     |               |      |             | 15   |             |    |    |    |                   |              |              |              |                 |      |
|     |               |      |             | 17.5 |             |    |    |    |                   |              |              |              |                 |      |

0.15 ≤ R < W/2 (R only)

Quotation

**Order**

(1) If shaped hole is at center of shank

Catalog No. V H L P W R (R only)

BBDD 25 13 20 P6.34 W4.65

(2) If shaped hole is not at center of shank

Catalog No. V H L P W R (R only) X-Y

BBDD 25 13 20 P6.34 W4.65 X6.35 Y9.5

⊕ Upper and lower limit values of X and Y

Hole shapes A  $2.5 + \frac{P}{2} \leq X \leq V - (2.5 + \frac{P}{2}) - (K + \frac{d}{2})$ ,  $2.5 + \frac{P}{2} \leq Y \leq H - (2.5 + \frac{P}{2})$

Hole shapes D R E G  $2.5 + \frac{P}{2} \leq X \leq V - (2.5 + \frac{P}{2}) - (K + \frac{d}{2})$ ,  $2.5 + \frac{W}{2} \leq Y \leq H - (2.5 + \frac{W}{2})$

⊕ If  $P < W$ , pay particular attention to the hole shape.

⊕ X, Y tolerance: ±0.005 (Shaped holes A), ±0.01 (Shaped holes D R E G)

⊕ Be aware that the shaped hole position and XY values are determined differently for block punches.

**Days to Ship** Quotation

**Price** Quotation

**Alterations**

Catalog No. V H L(LC) P-W-R (BC-LKC, etc.)

BBD 25 13 LC18 P1.50 BC3 LKC ANF1.2

| Alteration                 | Code | A  | D R E G  | 1Code     |
|----------------------------|------|--|--|-----------|
| Alterations to shaped hole | BC   | Shaped hole depth change<br>$1 \leq BC \leq 4$<br>0.1mm increments   |  |           |
|                            | PKC  | Shaped hole tolerance change<br>$P + 0.01 \rightarrow +0.005$  | Shaped hole tolerance change<br>$P - W \pm 0.01 \rightarrow +0.01$ |           |
| Alterations to full length | LC   | Full length change<br>$16 < LC < 35$<br>0.1mm increments<br>(if combined with LKC-LKZ, 0.01mm increments can be selected.) |  | Quotation |
|                            | LKC  | Full length tolerance change<br>$L + 0.4 \rightarrow +0.05$<br>$+0.2 \rightarrow 0$  |  |           |
|                            | LKZ  | Full length tolerance change<br>$L + 0.4 \rightarrow +0.01$<br>$+0.2 \rightarrow 0$  |  |           |

| Alteration | Code   | A  | D R E G  | 1Code     |        |   |     |    |     |    |     |    |      |    |      |    |      |  |
|------------|--------|--|--|-----------|--------|---|-----|----|-----|----|-----|----|------|----|------|----|------|--|
| Others     | VKC1   | V-H tolerance change<br>$V \cdot H + 0.01 \rightarrow V \cdot H + 0.005$<br>$0 \rightarrow 0$  |  |           |        |   |     |    |     |    |     |    |      |    |      |    |      |  |
|            | VKC2   | V-H tolerance change<br>$V \cdot H + 0.01 \rightarrow V \cdot H - 0.005$<br>$0 \rightarrow 0$  |  |           |        |   |     |    |     |    |     |    |      |    |      |    |      |  |
|            | NDC    | No press-in lead   |  | Quotation |        |   |     |    |     |    |     |    |      |    |      |    |      |  |
|            | ANF    | Angular angle change<br>$0 \leq ANF \leq 1.2$<br>0.2° increments<br>⊕ $d \leq d_{max}$<br>⊕ $d = P + 2 \cdot (L - B) \cdot \tan(ANF)$<br>⊕ $P - B \cdot \tan(ANF) \geq 0.6$<br>⊕ $W - B \cdot \tan(ANF) \geq 0.6$<br>⊗ Cannot be used if shaped hole is not at the center. | <table border="1"> <thead> <tr><th>H</th><th>d max.</th></tr> </thead> <tbody> <tr><td>8</td><td>4.4</td></tr> <tr><td>10</td><td>6.4</td></tr> <tr><td>13</td><td>8.4</td></tr> <tr><td>16</td><td>10.6</td></tr> <tr><td>20</td><td>12.6</td></tr> <tr><td>25</td><td>14.6</td></tr> </tbody> </table> Taper 1/50<br>Angle one side 0.573° | H         | d max. | 8 | 4.4 | 10 | 6.4 | 13 | 8.4 | 16 | 10.6 | 20 | 12.6 | 25 | 14.6 |  |
| H          | d max. |  |  |           |        |   |     |    |     |    |     |    |      |    |      |    |      |  |
| 8          | 4.4    |  |  |           |        |   |     |    |     |    |     |    |      |    |      |    |      |  |
| 10         | 6.4    |  |  |           |        |   |     |    |     |    |     |    |      |    |      |    |      |  |
| 13         | 8.4    |  |  |           |        |   |     |    |     |    |     |    |      |    |      |    |      |  |
| 16         | 10.6   |  |  |           |        |   |     |    |     |    |     |    |      |    |      |    |      |  |
| 20         | 12.6   |  |  |           |        |   |     |    |     |    |     |    |      |    |      |    |      |  |
| 25         | 14.6   |  |  |           |        |   |     |    |     |    |     |    |      |    |      |    |      |  |

**Example** **Features**

- Maintenance is possible without disassembling the die.
- The use of shims allows fine adjustments to be made even after the die is assembled.

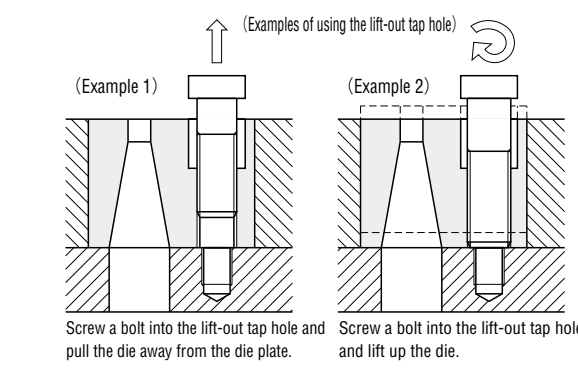

# SCRAP RETENTION BLOCK DIES

—FIXING-BOLT TYPE—



|                                |   |
|--------------------------------|---|
| Equivalent to SKD11 60 ~ 63HRC | <b>A</b> SR-BBD<br><b>D</b> SR-BBDD<br><b>R</b> SR-BBDR<br><b>E</b> SR-BBDE<br><b>G</b> SR-BBDG |
|                                | RoHS  |

**Hole shape A**

**Hole shape D**

**Hole shape R**

**Hole shape E**

**Hole shape G**

- ⊙ If  $P \geq W$   
 $P - 0.4 \geq 1.5$   
 (P dimension straight section 1.5 mm or longer)
- ⊙ If  $P < W$   
 $W - 0.4 \geq 1.5$   
 (W dimension straight section 1.5 mm or longer)
- ⊙ If  $P \geq W$   
 $0.15 \leq R < \frac{W}{2}$   
 $P - 2R \geq 1.5$   
 (P dimension straight section 1.5 mm or longer)
- ⊙ If  $P < W$   
 $0.15 \leq R < \frac{P}{2}$   
 $W - 2R \geq 1.5$   
 (W dimension straight section 1.5 mm or longer)
- ⊙ P=W cannot be selected.
- ⊙ If  $P < W$ , pay particular attention to hole shape.
- ⊙ P cannot be selected.
- ⊙ If  $P > W$   
 $\sqrt{W^2 - P^2} \geq 1.5$   
 (P dimension straight section 1.5 mm or longer)
- ⊙ If  $P < W$   
 $\sqrt{W^2 - P^2} \geq 1.5$   
 (W dimension straight section 1.5 mm or longer)  
 Pay particular attention to hole shape.

⊙ For the lift-out tap hole, use a bolt 1 size larger than the mounting bolt.

| Mounting bolt | M (Lift-out tap hole) |
|---------------|-----------------------|
| M3            | M4                    |
| M4            | M5                    |
| M6            | M8                    |
| M8            | M10                   |

| K   | Mounting bolt |             |             | J    | Catalog No. | V  | H  | L  | 0.01mm increments |              |                         |           | MT           | C            | Base unit price |              |              |
|-----|---------------|-------------|-------------|------|-------------|----|----|----|-------------------|--------------|-------------------------|-----------|--------------|--------------|-----------------|--------------|--------------|
|     | d             | h           | Size        |      |             |    |    |    | A                 | D            | R                       | E         |              |              | G               | 1 ~ 9 pieces |              |
|     | min. P max.   | min. P max. | min. W max. |      |             |    |    |    | R                 | SR-BBD       | SR-BBDG                 |           |              |              |                 |              |              |
| 4   | 6             | 7.5         | M3          | 3    | SR-BBD      | 13 | 8  | 16 | 1.00 ~ 3.00       | 1.00 ~ 3.00  | 0.15 ≤ R < W/2 (R only) | C ≥ 0.010 | 1.00 ~ 4.00  | 1.00 ~ 4.00  | 1.00 ~ 4.00     | 1.00 ~ 4.00  |              |
|     |               |             |             | 4    |             | 16 |    |    | 1.00 ~ 4.00       | 1.00 ~ 4.00  |                         |           |              |              |                 |              | 1.00 ~ 4.00  |
|     |               |             |             | 5    |             | 18 |    |    | 1.00 ~ 6.00       | 1.00 ~ 6.00  |                         |           |              |              |                 |              | 1.00 ~ 6.00  |
|     |               |             |             | 6.5  |             | 20 |    |    | 1.00 ~ 9.00       | 1.00 ~ 9.00  |                         |           |              |              |                 |              | 1.00 ~ 6.00  |
| 5   | 8             | 8.5         | M4          | 4    | SR-BBD      | 18 | 10 | 16 | 1.00 ~ 4.00       | 1.00 ~ 4.00  | 0.15 ≤ R < W/2 (R only) | C ≥ 0.010 | 1.00 ~ 6.00  | 1.00 ~ 6.00  | 1.00 ~ 6.00     | 1.00 ~ 6.00  |              |
|     |               |             |             | 5    |             | 20 |    |    | 1.00 ~ 6.00       | 1.00 ~ 6.00  |                         |           |              |              |                 |              | 1.00 ~ 6.00  |
|     |               |             |             | 6.5  |             | 22 |    |    | 1.00 ~ 9.00       | 1.00 ~ 9.00  |                         |           |              |              |                 |              | 1.00 ~ 6.00  |
|     |               |             |             | 8    |             | 25 |    |    | 1.00 ~ 12.00      | 1.00 ~ 12.00 |                         |           |              |              |                 |              | 1.00 ~ 6.00  |
| 6.5 | 11            | 10.5        | M6          | 5    | SR-BBDD     | 22 | 13 | 22 | 1.00 ~ 6.00       | 1.00 ~ 6.00  | 0.15 ≤ R < W/2 (R only) | C ≥ 0.010 | 1.00 ~ 9.00  | 1.00 ~ 9.00  | 1.00 ~ 9.00     | 1.00 ~ 9.00  |              |
|     |               |             |             | 6.5  |             | 25 |    |    | 1.00 ~ 9.00       | 1.00 ~ 9.00  |                         |           |              |              |                 |              | 1.00 ~ 9.00  |
|     |               |             |             | 8    |             | 28 |    |    | 1.50 ~ 16.00      | 1.50 ~ 16.00 |                         |           |              |              |                 |              | 1.00 ~ 9.00  |
|     |               |             |             | 10   |             | 32 |    |    | 1.00 ~ 9.00       | 1.00 ~ 9.00  |                         |           |              |              |                 |              | 1.00 ~ 9.00  |
| 8   | 14            | 12.5        | M8          | 8    | SR-BBDR     | 25 | 16 | 25 | 1.00 ~ 12.00      | 1.00 ~ 12.00 | 0.15 ≤ R < W/2 (R only) | C ≥ 0.010 | 1.00 ~ 12.00 | 1.00 ~ 12.00 | 1.00 ~ 12.00    | 1.00 ~ 12.00 |              |
|     |               |             |             | 10   |             | 32 |    |    | 1.50 ~ 16.00      | 1.50 ~ 16.00 |                         |           |              |              |                 |              | 1.00 ~ 12.00 |
|     |               |             |             | 12.5 |             | 38 |    |    | 1.50 ~ 21.00      | 1.50 ~ 21.00 |                         |           |              |              |                 |              | 1.00 ~ 12.00 |
|     |               |             |             | 15   |             | 40 |    |    | 1.50 ~ 16.00      | 1.50 ~ 16.00 |                         |           |              |              |                 |              | 1.50 ~ 16.00 |
| 8   | 14            | 12.5        | M8          | 10   | SR-BBDE     | 35 | 20 | 35 | 1.50 ~ 16.00      | 1.50 ~ 16.00 | 0.15 ≤ R < W/2 (R only) | C ≥ 0.010 | 1.50 ~ 16.00 | 1.50 ~ 16.00 | 1.50 ~ 16.00    | 1.50 ~ 16.00 |              |
|     |               |             |             | 12.5 |             | 40 |    |    | 1.50 ~ 21.00      | 1.50 ~ 21.00 |                         |           |              |              |                 |              | 1.50 ~ 16.00 |
|     |               |             |             | 15   |             | 45 |    |    | 1.50 ~ 26.00      | 1.50 ~ 26.00 |                         |           |              |              |                 |              | 1.50 ~ 16.00 |
|     |               |             |             | 17.5 |             | 50 |    |    | 1.50 ~ 31.00      | 1.50 ~ 31.00 |                         |           |              |              |                 |              | 1.50 ~ 21.00 |

⊙ Can be used only for workpiece materials with tensile strengths up to 1177 N/mm<sup>2</sup> (120 kgf/mm<sup>2</sup>).  
 ⊙ Workpiece material thickness and clearance are used as machining data for the scrap retention. Specify the shaped hole dimensions (P·W·R) when selecting the block die finishing dimensions.

**Order**

(1) If shaped hole is at center of shank

Catalog No. V H L P W R (R only) MT C

SR-BBDD 25 13 20 P6.34 W4.65 R MT1.50 C0.105

(2) If shaped hole is not at center of shank (hole shapes A only)

Catalog No. V H L P MT C X-Y

SR-BBD 25 13 20 P6.34 MT1.50 C0.105 X6.35 Y9.5

⊙ Upper and lower limit values of X and Y

Hole shapes A  $2.5 + \frac{P}{2} \leq X \leq V - (2.5 + \frac{P}{2}) - (K + \frac{d}{2})$   $2.5 + \frac{P}{2} \leq Y \leq H - (2.5 + \frac{P}{2})$

⊙ X, Y tolerance: ±0.005

⊙ Be aware that the shaped hole position and X/Y values are determined differently for block punches.

**Days to Ship** Quotation

**Price** Quotation

**Alterations**

Catalog No. V H L(LC) P-W-R MT C (BC-LKC, etc.)

SR-BBD 25 13 LC18 P1.5 0.5 0.04 BC3 LKC ANF1.2

| Alteration                 | Code | A  | D R E G   | 1Code     |
|----------------------------|------|--|---|-----------|
| Alterations to shaped hole | BC   | Shaped hole depth change<br>$1 \leq BC \leq B_{max}$<br>0.1mm increments   | Shaped hole depth change<br>$1 \leq BC < 2$<br>0.1mm increments                             | Quotation |
|                            | PKC  | Shaped hole tolerance change<br>$P + 0.01 \rightarrow +0.005$<br>$0 \rightarrow 0$   | Shaped hole tolerance change<br>$P \cdot W \pm 0.01 \rightarrow +0.01$<br>$0 \rightarrow 0$ |           |
| Alterations to full length | LC   | Full length change<br>$16 < LC < 35$<br>0.1mm increments<br>(If combined with LKC-LKZ, 0.01mm increments can be selected.) |   | Quotation |
|                            | LKC  | Full length tolerance change<br>$L + 0.4 \rightarrow +0.05$<br>$0 \rightarrow 0$   |   |           |
|                            | LKZ  | Full length tolerance change<br>$L + 0.4 \rightarrow +0.01$<br>$0 \rightarrow 0$   |   |           |

| Alteration | Code   | A  | D R E G   | 1Code     |        |   |     |    |     |    |     |    |      |    |      |    |      |  |
|------------|--------|--|---|-----------|--------|---|-----|----|-----|----|-----|----|------|----|------|----|------|--|
| Others     | VKC1   | V-H tolerance change<br>$V \cdot H + 0.01 \rightarrow +0.005$<br>$0 \rightarrow 0$   |   | Quotation |        |   |     |    |     |    |     |    |      |    |      |    |      |  |
|            | VKC2   | V-H tolerance change<br>$V \cdot H + 0.01 \rightarrow -0.005$<br>$0 \rightarrow 0$   |   |           |        |   |     |    |     |    |     |    |      |    |      |    |      |  |
|            | NDC    | No press-in lead   |   |           |        |   |     |    |     |    |     |    |      |    |      |    |      |  |
|            | ANF    | Angular angle change<br>$0 \leq ANF \leq 1.2$<br>0.2° increments<br>$d \leq d_{max}$<br>$d = P + 2 \cdot (L - B) \cdot \tan(ANF)$<br>$P - B \cdot \tan(ANF) \geq 0.6$<br>$W - B \cdot \tan(ANF) \geq 0.6$<br>⊙ Cannot be used if shaped hole is not at the center. | <table border="1"> <tr> <th>H</th> <th>d max.</th> </tr> <tr> <td>8</td> <td>4.4</td> </tr> <tr> <td>10</td> <td>6.4</td> </tr> <tr> <td>13</td> <td>8.4</td> </tr> <tr> <td>16</td> <td>10.6</td> </tr> <tr> <td>20</td> <td>12.6</td> </tr> <tr> <td>25</td> <td>14.6</td> </tr> </table> | H         | d max. | 8 | 4.4 | 10 | 6.4 | 13 | 8.4 | 16 | 10.6 | 20 | 12.6 | 25 | 14.6 |  |
| H          | d max. |  |   |           |        |   |     |    |     |    |     |    |      |    |      |    |      |  |
| 8          | 4.4    |  |   |           |        |   |     |    |     |    |     |    |      |    |      |    |      |  |
| 10         | 6.4    |  |   |           |        |   |     |    |     |    |     |    |      |    |      |    |      |  |
| 13         | 8.4    |  |   |           |        |   |     |    |     |    |     |    |      |    |      |    |      |  |
| 16         | 10.6   |  |   |           |        |   |     |    |     |    |     |    |      |    |      |    |      |  |
| 20         | 12.6   |  |   |           |        |   |     |    |     |    |     |    |      |    |      |    |      |  |
| 25         | 14.6   |  |   |           |        |   |     |    |     |    |     |    |      |    |      |    |      |  |

**Example** **Features**

- Maintenance is possible without disassembling the die.
- The use of shims allows fine adjustment even after the is assembled.

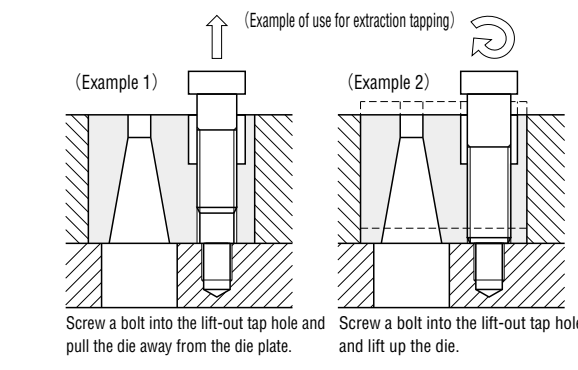

# BLOCK DIE BLANKS

# BLOCK DIE BLANKS

—FIXING-BOLT TYPE—

—Straight— **RoHS** **BLDB** (Equivalent to SKD11)  
**PBLDB** (Powdered high-speed steel)

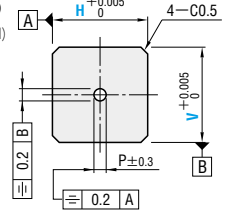

—Single flange—

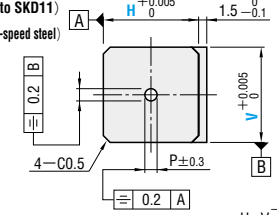

**BLDBF** (Equivalent to SKD11)  
**PBLDBF** (Powdered high-speed steel)

—BLDB - BLDBF  
 Equivalent to SKD11  
 60 ~ 63HRC

—PBLDB - PBLDBF  
 Powdered high-speed steel  
 64 ~ 67HRC

| Catalog No.                      | V  |   |   |    |    |    |    |    | L                                | P   |
|----------------------------------|----|---|---|----|----|----|----|----|----------------------------------|-----|
|                                  | H  | 6 | 8 | 10 | 13 | 16 | 20 | 25 |                                  |     |
| Straight<br>BLDB<br>PBLDB        | 6  | ○ | ○ | ○  | ○  | ○  | ○  | ○  | 16<br>20<br>22<br>25<br>30<br>35 | 0.8 |
|                                  | 8  |   |   |    |    |    |    |    |                                  |     |
|                                  | 10 |   |   |    |    |    |    |    |                                  |     |
|                                  | 13 |   |   |    |    |    |    |    |                                  |     |
|                                  | 16 |   |   |    |    |    |    |    |                                  |     |
| Single flange<br>BLDBF<br>PBLDBF | 16 |   |   |    |    |    |    |    |                                  |     |
|                                  | 20 |   |   |    |    |    |    |    |                                  |     |
|                                  | 25 |   |   |    |    |    |    |    |                                  |     |
|                                  | 25 |   |   |    |    |    |    |    |                                  |     |

Order **Catalog No.** **V** **H** — **L**  
**PBLDB** **08** **06** — **16**

Days to Ship **Quotation**

Price **Quotation**

Alterations **Catalog No.** **V** **H** — **L(LC)** — (HC-TC-TKC, etc.)  
**BLDBF** **13** **10** — **20** — **TC4**

■ Base unit price

| Catalog No. | V  |   |   |    |    |    |    |    |
|-------------|----|---|---|----|----|----|----|----|
|             | H  | 6 | 8 | 10 | 13 | 16 | 20 | 25 |
| BLDB        | 6  |   |   |    |    |    |    |    |
|             | 8  |   |   |    |    |    |    |    |
|             | 10 |   |   |    |    |    |    |    |
|             | 13 |   |   |    |    |    |    |    |
|             | 16 |   |   |    |    |    |    |    |
| PBLDB       | 6  |   |   |    |    |    |    |    |
|             | 8  |   |   |    |    |    |    |    |
|             | 10 |   |   |    |    |    |    |    |
|             | 13 |   |   |    |    |    |    |    |
|             | 16 |   |   |    |    |    |    |    |
| BLDBF       | 6  |   |   |    |    |    |    |    |
|             | 8  |   |   |    |    |    |    |    |
|             | 10 |   |   |    |    |    |    |    |
|             | 13 |   |   |    |    |    |    |    |
|             | 16 |   |   |    |    |    |    |    |
| PBLDBF      | 6  |   |   |    |    |    |    |    |
|             | 8  |   |   |    |    |    |    |    |
|             | 10 |   |   |    |    |    |    |    |
|             | 13 |   |   |    |    |    |    |    |
|             | 16 |   |   |    |    |    |    |    |

| Alteration                 | Code | Spec.   | 1Code |
|----------------------------|------|---|-------|
| Alterations to full length | LC   | Full length change 10 ≤ LC < L<br>0.1mm increments<br>(If combined with LKC-LKZ, 0.01mm increments can be selected.)<br>For single flange types, if LC ≤ 12 then press-in lead is not included.                       |       |
|                            | LKC  | Full length tolerance change<br>L +0.4 → +0.05<br>+0.2 → 0  |       |
|                            | LKZ  | Full length tolerance change<br>L +0.4 → +0.01<br>+0.2 → 0  |       |
| Alterations to flange      | HC   | Flange width change<br>0 ≤ HC < 1.5<br>0.1mm increments   |       |
|                            | TC   | Flange thickness change 2 ≤ TC < 5<br>0.1mm increments<br>(If combined with TKC-TKM, 0.01mm increments can be selected.)<br>Full length L is shortened by (5-TC).<br>If combined with LC, full length is equal to LC. |       |
| Others                     | VHM  | Shape tolerance change H·V +0.005 → 0 -0.005  |       |
|                            | NDC  | No press-in lead  |       |
|                            | NHC  | No start hole (P)   |       |

**RoHS** **BBDB**

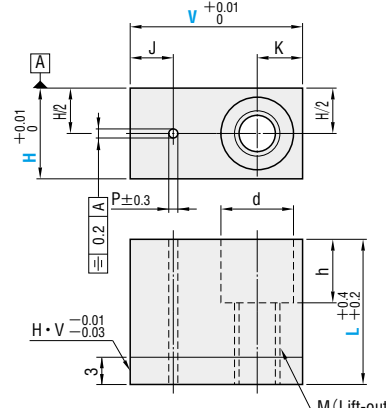

For the lift-out tap hole, use a bolt 1 size larger than the mounting bolt.

| Mounting bolt | M (lift-out tap hole) |
|---------------|-----------------------|
| M3            | M4                    |
| M4            | M5                    |
| M6            | M8                    |
| M8            | M10                   |

Equivalent to SKD11  
 60 ~ 63HRC

| K   | Mounting bolt |      |      | J    | Catalog No. | V                    | H  | L  | P   | Base unit price<br>1 ~ 9 pieces |      |                |    |     |           |
|-----|---------------|------|------|------|-------------|----------------------|----|----|-----|---------------------------------|------|----------------|----|-----|-----------|
|     | d             | h    | Size |      |             |                      |    |    |     |                                 |      |                |    |     |           |
| 4   | 6             | 7.5  | M3   | 3    | BBDB        | 13<br>16<br>18<br>20 | 8  | 16 | 0.8 | Quotation                       |      |                |    |     |           |
|     |               |      |      | 4    |             |                      |    |    |     |                                 |      |                |    |     |           |
|     |               |      |      | 5    |             |                      |    |    |     |                                 |      |                |    |     |           |
|     |               |      |      | 6.5  |             |                      |    |    |     |                                 |      |                |    |     |           |
|     |               |      |      | 8    |             |                      |    |    |     |                                 |      |                |    |     |           |
| 5   | 8             | 8.5  | M4   | 4    | BBDB        | 18<br>20<br>22<br>25 | 10 | 20 | 0.8 | Quotation                       |      |                |    |     |           |
|     |               |      |      | 5    |             |                      |    |    |     |                                 |      |                |    |     |           |
|     |               |      |      | 6.5  |             |                      |    |    |     |                                 |      |                |    |     |           |
|     |               |      |      | 8    |             |                      |    |    |     |                                 |      |                |    |     |           |
|     |               |      |      | 10   |             |                      |    |    |     |                                 |      |                |    |     |           |
| 6.5 | 11            | 10.5 | M6   | 5    | BBDB        | 22<br>25<br>28<br>32 | 13 | 22 | 0.8 | Quotation                       |      |                |    |     |           |
|     |               |      |      | 6.5  |             |                      |    |    |     |                                 |      |                |    |     |           |
|     |               |      |      | 8    |             |                      |    |    |     |                                 |      |                |    |     |           |
|     |               |      |      | 10   |             |                      |    |    |     |                                 |      |                |    |     |           |
|     |               |      |      | 12.5 |             |                      |    |    |     |                                 |      |                |    |     |           |
|     |               |      |      | 8    |             |                      |    |    |     |                                 | BBDB | 16<br>20<br>25 | 25 | 0.8 | Quotation |
|     |               |      |      | 10   |             |                      |    |    |     |                                 |      |                |    |     |           |
|     |               |      |      | 12.5 |             |                      |    |    |     |                                 |      |                |    |     |           |
|     |               |      |      | 15   |             |                      |    |    |     |                                 |      |                |    |     |           |
|     |               |      |      | 17.5 |             |                      |    |    |     |                                 |      |                |    |     |           |
| 8   | 14            | 12.5 | M8   | 8    | BBDB        | 32<br>35<br>40<br>45 | 20 | 30 | 0.8 | Quotation                       |      |                |    |     |           |
|     |               |      |      | 10   |             |                      |    |    |     |                                 |      |                |    |     |           |
|     |               |      |      | 12.5 |             |                      |    |    |     |                                 |      |                |    |     |           |
|     |               |      |      | 15   |             |                      |    |    |     |                                 |      |                |    |     |           |
|     |               |      |      | 17.5 |             |                      |    |    |     |                                 |      |                |    |     |           |

Order **Catalog No.** **V** **H** — **L**  
**BBDB** **25** **13** — **20**

Days to Ship **Quotation**

Price **Quotation**

Alterations **Catalog No.** **V** **H** — **L(LC)** — (CC-LKC, etc.)  
**BBDB** **25** **13** — **LC18.0** — **LKC**

| Alteration                 | Code | Spec.  | 1Code |
|----------------------------|------|--|-------|
| Alterations to full length | LC   | Full length change 16 < LC < L<br>0.1mm increments<br>(If combined with LKC-LKZ, 0.01mm increments can be selected.) |       |
|                            | LKC  | Full length tolerance change<br>L +0.4 → +0.05<br>+0.2 → 0   |       |
|                            | LKZ  | Full length tolerance change<br>L +0.4 → +0.01<br>+0.2 → 0   |       |

| Alteration | Code | Spec.  | 1Code |
|------------|------|--|-------|
| Others     | VKC1 | V·H tolerance change<br>V·H +0.01 → V·H +0.005   |       |
|            | VKC2 | V·H tolerance change<br>V·H +0.01 → V·H 0 -0.005 |       |
|            | CC   | C0.5 chamfering to 4 outer (V·H) corners         |       |
|            | NDC  | No press-in lead                                 |       |
|            | NHC  | No start hole (P)                                |       |

RoHS

SK5  
45HRC ~

**Hole shape A**:  $4-C0.5$ ,  $H-0.1$ ,  $V-0.1$ ,  $P+0.05$

**Hole shape D**:  $P+0.05$ ,  $W+0.05$ ,  $R \leq 0.2$

**Hole shape R**:  $P+0.05$ ,  $W+0.1$ ,  $R$

**Hole shape E**:  $P+0.05$ ,  $W+0.05$

**Hole shape G**:  $P+0.05$ ,  $W+0.05$

⊕ The outside diameter has slight depression. ⊕ P→min.W max. P dimension must be within the range of dimension W.

⊕ P ≥ W      ⊕ P ≥ W      ⊕ P > W      ⊕ P > W

⊕  $0.15 \leq R < \frac{W}{2}$

| Catalog No.   | H  | V            |             | 6            | 8            | 10           | 13            | 16            | 20            | 25            | R                          | t    |
|---------------|----|--------------|-------------|--------------|--------------|--------------|---------------|---------------|---------------|---------------|----------------------------|------|
|               |    | min. W max.  | min. P max. | 1.00<br>4.00 | 1.00<br>6.00 | 1.00<br>8.00 | 1.00<br>10.00 | 1.00<br>12.00 | 1.50<br>16.00 | 1.50<br>20.00 | Ⓡ                          |      |
| <b>A</b> SBD  | 6  | 1.00 ~ 4.00  |             | ○            | ○            | ○            | ○             | ○             | ○             | ○             | 0.15 ≤ R < W/2<br>(Ⓡ only) | 0.05 |
|               | 8  | 1.00 ~ 6.00  |             |              | ○            | ○            | ○             | ○             | ○             | ○             |                            | 0.1  |
| <b>D</b> SBDD | 10 | 1.00 ~ 8.00  |             |              |              | ○            | ○             | ○             | ○             | ○             |                            | 0.2  |
| <b>R</b> SBDR | 13 | 1.00 ~ 10.00 |             |              |              |              | ○             | ○             | ○             | ○             |                            | 0.3  |
| <b>E</b> SBDE | 16 | 1.00 ~ 12.00 |             |              |              |              |               | ○             | ○             | ○             |                            | 0.5  |
|               | 20 | 1.50 ~ 16.00 |             |              |              |              |               |               | ○             | ○             |                            | 1.0  |
| <b>G</b> SBDG | 25 | 1.50 ~ 20.00 |             |              |              |              |               |               |               | ○             |                            | 1.5  |
|               |    |              |             |              |              |              |               |               |               |               | 2.0                        |      |

⊕ 1 set consists of 8-piece (1 of each t dimension).      ⊕ P·W·R→0.01mm increments

Order **Catalog No.** **V** **H** — **0.01mm increments**

**SBDE** **13** **10** — **P8.50** — **W6.50** — **R(Ⓡ only)**

Days to Ship **Quotation**

Price **Quotation**

Alterations **Catalog No.** **V** **H** — **P** — **W** — **R** — (HVC)

**SBDR** **25** **20** — **P16.55** — **W12.55** — **R2.00** — **HVC**

| Alteration                 | Code       | Spec.  | 1Code            |
|----------------------------|------------|--|------------------|
| Alterations to shaped hole | <b>HVC</b> | H and V are reversed relative to shaped hole. P dimension is machined in direction H and W dimension is machined in direction V.<br>⊕ P→min. W max. ⊕ A Cannot be used with SBD. | <b>Quotation</b> |

■ Spacer layer plates P.839 RoHS

**LHP** : Individual piece (no hole)  
**LHP-H** : Individual piece (with hole)  
**LHP-SET** : Set of layer plates (in desired combination)

■ Precision multipurpose plates P.841 RoHS

**UTPB** : Fixed L dimension (150mm)  
**UTPL** : L dimension specified (10 ~ 150mm)

T dimension (thickness) : 0.05mm ~

T dimension (thickness) : 0.3mm ~

■ Shim tape P.840 RoHS

**FGSM** : Width 12.7mm Length 1m  
**FGSMW** : Width 45.0mm Length 1m  
**FGSML** : Width 12.7mm Length 5m (Value package)

T dimension (thickness) : 0.005mm ~